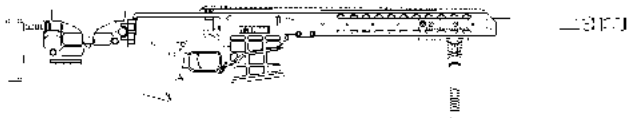




# MRAD

(Multi-Role Adaptive Design)



## Operator's Manual

PO Box 1077 Murfreesboro, TN 37133 USA / 615.8962938 / 615.896.7313 FAX / mail@barrett.net

03-23-11

P# 12925

## Use of this manual

Before you handle the MRAD rifle, read this manual in its entirety. It is important that you understand the principles of safe gun handling in general and the unique features of this rifle. This manual is not a substitute for training from a qualified instructor. Important safety topics are discussed in this chapter and throughout this manual. This manual should remain with the rifle and it should be transferred with the rifle to subsequent owners. Additional manuals can be ordered from Barrett Firearms Manufacturing or can be downloaded from the company website, [www.barrett.net](http://www.barrett.net). This manual covers the MRAD only. Technical specifications are subject to change without notice.

## SAFETY GUIDELINES

### WARNING

Failure to follow safety guidelines may cause injury or death.

## Ammunition

Barrett does not condone the use of handloaded, remanufactured, or surplus ammunition. The use of clean, dry, properly stored, and correct caliber ammunition will preserve your warranty.

## Safety distance

Bullets fired from this rifle may travel as far as 4 miles. Make certain that you have an adequate backstop.

## Hearing protection

Hearing loss is permanent. Hearing loss from gunfire is cumulative, but the noise from even one shot may cause permanent loss. Wear both ear plugs and ear muffs. It is also your responsibility to protect the hearing of those around you. The muzzle brake is integral to the design of your rifle and works to divert a large portion of a shot's blast to the side of the muzzle. Your rifle must not be fired without it. People and objects should not be in the vicinity of the muzzle brake because its blast consists of high pressure and high temperature gas. All spectators should use double hearing protection. The safest place for a spectator is directly behind the shooter.

### **Eye protection**

Eye protection should be worn when shooting and maintaining your rifle. It is normal for firing to generate airborne dust and debris. Protect your eyes from solvents and uncaptured parts under spring pressure while performing maintenance on your rifle.

### **Assume every gun is loaded**

Always treat every gun as if it were loaded. Look and feel for an empty chamber. Do not trust your memory and do not take anyone else's word for it. Do not trust the extractor to provide an empty chamber.

### **Beware of barrel obstructions**

Ensure the barrel's bore is free of obstructions before you fire your rifle. Even the smallest obstruction such as a stuck patch or even grease will cause dangerously increased pressures that can rupture the barrel.

### **Muzzle control**

Always keep the muzzle pointed in a safe direction. Never allow your muzzle to point at anything that you do not intend to shoot.

### **Keep your finger off the trigger**

Keep your finger off the trigger and out of the trigger guard until your sights are aligned on your target and you intend to fire.

### **Keep your safety on**

Keep your safety on until your sights are aligned on your target and you intend to fire.

### **Identify your target and backstop**

Before you pull the trigger, make certain of your target and what is in front of, around and beyond it. The rifle should never be fired at surfaces where bullets are likely to glance off in unpredictable directions.

### **Failure to fire**

If your rifle fails to fire when you pull the trigger, do not lift the bolt handle to open the action. Keep the rifle pointed toward a safe area and wait 2

minutes. If a hangfire (slow ignition) has occurred, the round will probably fire within two minutes. If the round does not fire, remove and inspect the cartridge. If the primer is indented properly, discard the cartridge in a safe manner. If the primer is lightly dented, refer to the troubleshooting chart in this manual.

### **Maintain your rifle properly**

Performing proper maintenance, as outlined in this manual, ensures that your rifle will be safe to shoot and will perform to design specification for many years. Alterations, modifications or adjustments may damage your rifle, make it unsafe to fire and will void warranty claims.

### **Store your rifle safely**

Even though your rifle represents a significant financial investment, the greatest value in keeping it secured is preventing it from falling into the hands of a child, a careless adult, or a thief. It is your responsibility to take every reasonable precaution to secure your rifle.

### **Alcohol, medications and drugs**

Do not handle or operate your rifle under the influence of alcohol, medication or drugs.

## **SUMMARY OF WARNINGS AND CAUTIONS**

### **WARNINGS Summary**

- Do not attempt to force a cartridge into the chamber by forcing the bolt closed. If the bolt will not close easily, remove the cartridge and examine it for damage or defects. Check the chamber for obstructions. *(Page 12)*
- The shooter must be positioned directly behind the rifle with the recoil pad held firmly against the shoulder. Firing the rifle in any other position could result in injury by contact with the rifle or rifle scope. *(Page 12)*
- Unload and clear the rifle before disassembly.
- Ensure no live ammunition is present during disassembly or assembly. *(Page 15)*
- Do not remove the coin or other object from the cocking piece while the firing pin assembly is removed from the bolt tube complete. The firing pin

spring is under heavy load. Serious injury can occur if the assembly pin is removed. *(Page 25)*

- Adjusting the trigger weight too low may cause an accidental discharge. *(Page 31)*
- Physically check the chamber and make sure the rifle is not loaded. *(Page 35)*
- Unload and clear the rifle before cleaning. *(Page 36)*

### **CAUTIONS Summary**

- The bolt handle must be in the up position before the receivers can be unlatched. *(Page 14)*
- Do not force the bolt into place. *(Page 23)*
- Do not insert cleaning rods through the muzzle. The barrel crown could be damaged which would severely degrade the accuracy of the rifle. *(Page 36)*
- To protect the rifle from corrosion, the rifle and the interior of the carrying case should be moisture free before the rifle is placed in the carrying case for storage. *(Page 36)*

### **WARRANTY AND SERVICE**

Barrett Firearms Manufacturing Inc. (BFMI), warrants that this firearm was manufactured free of defects in materials and workmanship. For one year from the date of purchase by the original owner, BFMI agrees to correct any defect in this firearm for the original purchaser by repair or replacement with the same or comparable model.

BFMI will not be responsible for injury, death, or damage to property resulting from either intentional or accidental discharge of this firearm or from its function when used for purposes or subjected to treatment for which it was not designed. BFMI will not honor claims involving this firearm which result from careless or improper handling, unauthorized adjustment or parts replacement, corrosion, neglect, the use of the wrong caliber ammunition, or the use of other than commercially manufactured ammunition in good condition, or any combination thereof. BFMI will not honor claims involving this firearm when such claims are made by the second or subsequent owner.

If you need factory service, whether made under warranty or not, please contact BFMI for instructions on how to have your gun repaired.

Phone: 615.8962938

Fax: 615.896.2938

Email: [mail@barrett.net](mailto:mail@barrett.net)

Web Site: [barrett.net](http://barrett.net)

Address: P.O. Box 1077 Murfreesboro, TN USA 37133-1077

### **Your Responsibility**

Your Barrett rifle is well-engineered and manufactured to the highest standards. It was proof-fired and carefully inspected before it was packaged and shipped from our factory. Its safe use depends on you alone. You are the ultimate safety device. Much like other mechanical devices, such as electric power tools, gas-powered lawn equipment, and automobiles, your rifle is safe unless handled in an irresponsible or uneducated manner.

## TABLE OF CONTENTS

Use of this Manual-----	1
Safety Guidelines -----	1-3
Summary of Warnings and Cautions -----	3-4
Warranty and Service -----	4-5
Table of Contents-----	6
Specifications -----	7
Contents -----	8
Purpose and Capabilities -----	9
Function-----	9
Break-in Procedure -----	9
Loading-----	10-12
Unloading and Clearing -----	13
Operation Under Unusual Circumstances-----	13
Disassembly and Assembly -----	14-35
Field Stripping/Disassembly Into Major Components -----	14-16
Removing and Installing Accessory Rail -----	19
Reassembly of Major Components -----	17
Folding the Stock -----	17
Length-of-Pull Adjustment -----	18
Cheek-Piece Adjustment -----	18
Disassembly, Assembly, and Cleaning Magazine Assembly -----	18-19
Removal and Installation of the Barrel -----	20
Headspace Inspection -----	21-23
Caliber Conversion -----	23
Removal and Disassembly of the Bolt Carrier Assembly-----	24-26
Reassembly of the Bolt Carrier Assembly -----	27
Removal and Installation of Extractor -----	27-28
Adjusting the Trigger Mechanism -----	29-35
Cleaning and Lubrication -----	36
Preventative Maintenance Checks and Services-----	37-39
Inspection of Installed Items-----	40
Troubleshooting -----	41
Exploded View and Parts List -----	42-44

## **SPECIFICATIONS**

MODEL: MRAD (Multi-Role Adaptive Design)

CALIBER: .338 Lapua Magnum

BARREL LENGTH: 24.5" (62.23 cm)

OVERALL LENGTH: Folding stock extended: 46.90" (119.13 cm)

Folding stock closed: 39.90" (101.35 cm)

WEIGHT: 14.8 pounds (6.71 kg)

TWIST RATE: 1-10" Right-Hand Twist

SAFETY: Manually-operated reversible thumb-lever

SAFETY RANGE NEEDED: 4 miles (estimated)

SCOPE RAIL: Integral M1913 style, 21.75" (55.25 cm) with 30

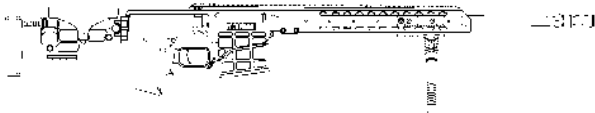
MOA taper

CARRYING CASE LENGTH: 53 inches

CARRYING CASE WIDTH: 16 inches

CARRYING CASE DEPTH: 6 inches

CARRYING CASE WEIGHT: 24 pounds



*Figure 1.*

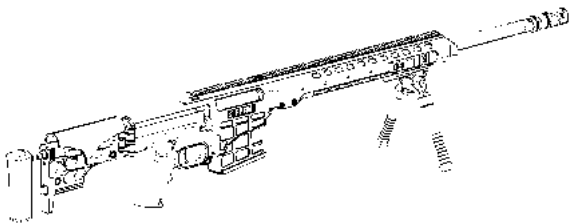


## CONTENTS

Your MRAD rifle includes the following:

- MRAD Rifle
- Two Magazines
- Hard Carrying Case with Foam Insert
- Operator's Manual
- Bolt-Carrier Disassembly Tool
- Two Short and One Long Accessory Rails

The rifle is shipped from the factory fully assembled. (Figure 2.)



**Figure 2.**

(Shown with optional accessories.)

## **PURPOSE AND CAPABILITIES OF FIREARM**

The MRAD is a long-range configurable sniper-rifle system designed to accurately and precisely engage targets at 1500 meters or beyond. The MRAD has been designed for complete system modularity, reduced logistical and operational burden, and maximum operator-level sustainability. The MRAD is capable of reconfiguration in less than two minutes with no need for re-zeroing, live fire, and without the use of tools by swapping modular upper receivers. Barrel changes for maintenance or reconfiguration can be completed with minimal use of tools and in under 10 minutes.

## **FUNCTION**

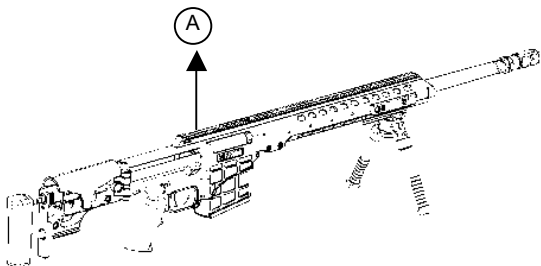
The MRAD is a magazine-fed, bolt-action rifle. The shooter manually cycles the action to feed a new cartridge from the magazine into the chamber. The firing pin assembly is cocked when the bolt handle is raised. The bolt is retained in the receiver and is equipped with an extractor to remove a cartridge or shell casing. A manually-controlled safety prevents or permits trigger movement.

## **BREAK-IN PROCEDURE**

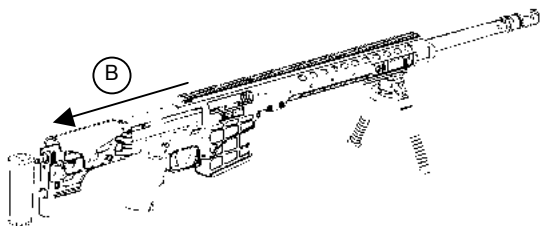
Because individual barrels, powder, primer and bullet combinations vary widely and because shooters have strongly held personal opinions on the subject, Barrett does not offer a specific procedure for barrel break-in. Barrett does recognize that a clean barrel shoots better. Barrett also recommends that you do not overheat your barrel, especially when new. Experience has shown that the bore becomes less prone to fouling over time and that accuracy may increase as this occurs.

## LOADING

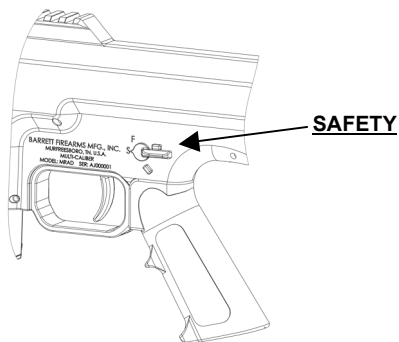
1. With the rifle pointed in a safe direction, lift the bolt handle (*Figure 3, Step A.*) and draw it to the rear of the rifle. (*Figure 3, Step B.*)
2. Rotate the safety lever to the "SAFE" (lever horizontal) position. (*Figure 4.*)



**Figure 3, Step A.**

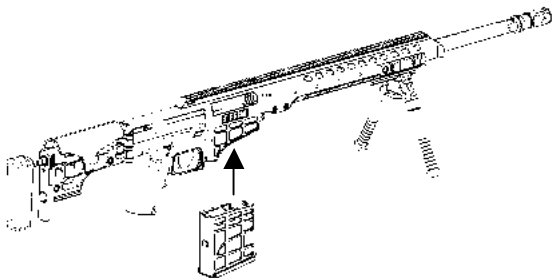


**Figure 3, Step B.**



**Figure 4.**  
(Safety lever to "SAFE".)

3. Insert a loaded magazine into the rifle. (*Figure 5.*) The magazine inserts straight into the magazine well from the bottom.

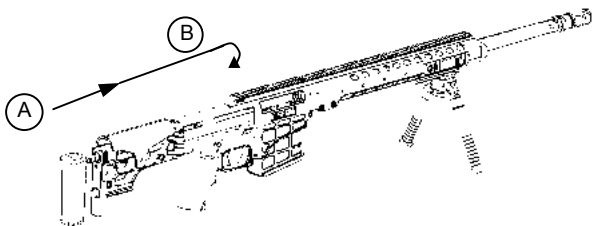


**Figure 5.**  
(Inserting the magazine.)

4. Push the bolt handle forward (*Figure 6, Step A.*) quickly and firmly to load a cartridge into the chamber. Rotate the bolt handle down (*Figure 6, Step B.*), to close the firing chamber.

### **WARNING**

Do not attempt to force a cartridge into the chamber by forcing the bolt closed. If the bolt will not close with moderate, but firm pressure, remove the cartridge and examine it for damage or defects. Check the chamber for obstructions.



**Figure 6, Step A and B.**  
(Closing the Bolt)

5. Rotate the safety to the “FIRE” position (45 degrees). The rifle is now ready to fire.

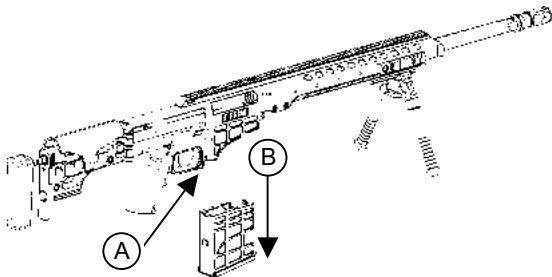
### **WARNING**

The shooter must be positioned directly behind the rifle with the recoil pad held firmly against the shoulder before firing. Firing the rifle in any other position could result in injury by contact with the rifle or rifle scope

6. The rifle will fire one (1) cartridge with each pull of the trigger each time the action is manually cycled.
7. To load a new cartridge, fully lift the bolt handle and draw it fully to the rear. This action will extract and eject the spent case from the chamber. Next, push the bolt handle forward and rotate downward. This feeds a new cartridge from the magazine into the chamber.

## UNLOADING AND CLEARING

1. Place the safety lever in the "SAFE" position.
2. Lift the bolt handle upward and pull it to the rear to eject a chambered cartridge or spent case.
3. Remove the magazine from the rifle by pushing the magazine catch forward and removing the magazine from the rifle. (*Figure 7, Step A and B.*)



**Figure 7, Step A and B.**

4. With the bolt pulled fully to the rear, look into the chamber to make sure that the cartridge or spent case has been removed and the chamber is now empty. Insert a finger into the chamber to verify the empty chamber.

## OPERATION UNDER UNUSUAL CONDITIONS

### Emergency Procedures

The rifle may be fired without the magazine. A single cartridge may be inserted directly into the chamber.

## DISASSEMBLY AND ASSEMBLY

### WARNING

Unload and clear the rifle before disassembly.  
Ensure no live ammunition is present during disassembly or assembly.

### CAUTION

The bolt handle must be in the up position before the receivers can be unlatched and separated.

### Field Stripping

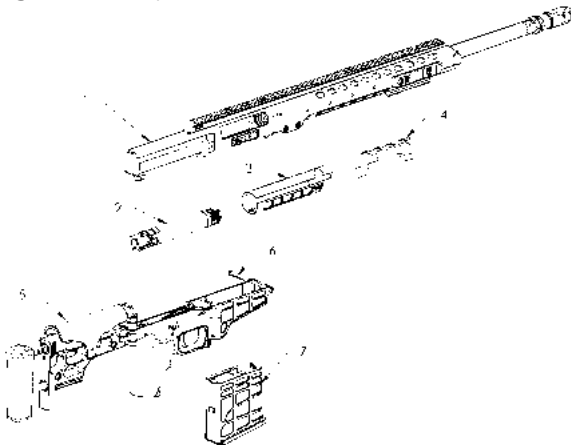
The rifle may be field stripped into 5 major components. (Figure 8.)

#### Major components:

- Upper Receiver Assembly (1)
- Bolt Carrier Assembly (2)
- Lower Receiver Assembly (5)
- Magazine Assembly (7)

#### Components:

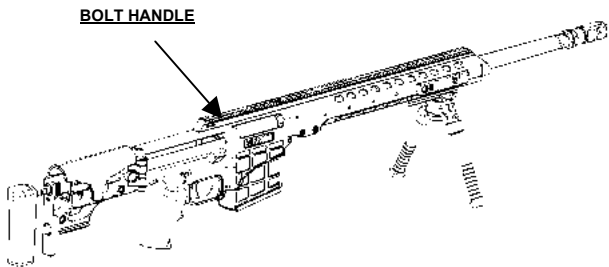
- Rear Bolt Guide (3)
- Front Bolt Guide (4)
- Assembly Pin (6)



**Figure 8.**  
(Major Components)

## Disassembly into Major Components

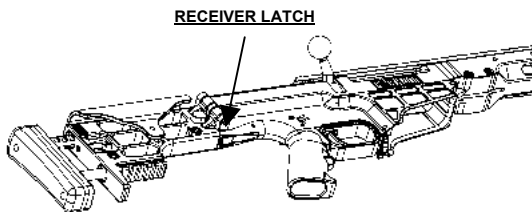
1. Deploy bipod legs (if attached) to let the rifle rest on the bipod feet and pistol grip of the rifle.
2. Ensure the safety lever is in the safe position and raise the bolt handle fully. (Figure 9.)



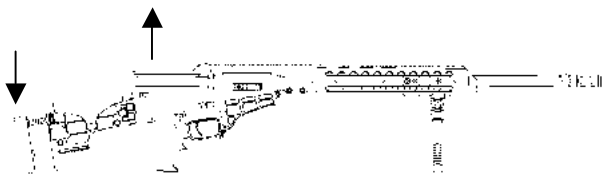
**Figure 9.**

3. Before separating the receivers, ensure bolt is clear of chamber. Depress and hold the receiver latch, located on the underside of the lower receiver just behind the pistol grip. (Figure 10, Step A.) Pivot the receivers apart until the upper receiver clears the lower receiver. (Figure 10, Step B) Release the receiver latch. Hold the receivers apart and withdraw the bolt carrier assembly, rear bolt guide, and the front bolt guide. Gently lower the upper receiver back down until it is resting on the latch mechanism. Do not latch the receivers back together at this time. Take notice of the orientation of the bolt guides when they are taken out of the receiver. The front bolt guide has a tab that protrudes forward. This tab orients at twelve o'clock in a slot in the receiver.



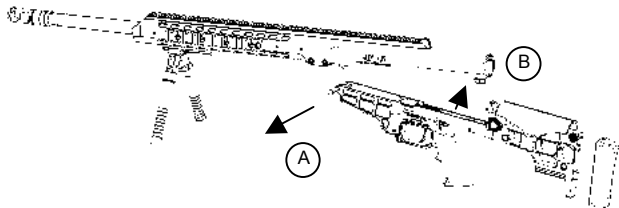


**Figure 10, Step A.**



**Figure 10, Step B.**

4. Separate the receiver and the lower receiver. (*Figure 10, Step B.*)
5. Slide the assembly pin to the left to separate the receivers. The pin cannot be completely removed, DO NOT force it out. (*Figure 11.*)



**Figure 11.**

**NOTE**

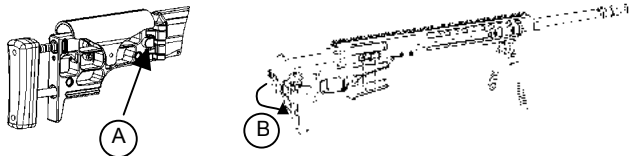
No further disassembly of the receivers are recommended or necessary for maintenance.

**Reassembly of Major Components**

Major components are assembled in reverse order of disassembly.

**Folding the Stock**

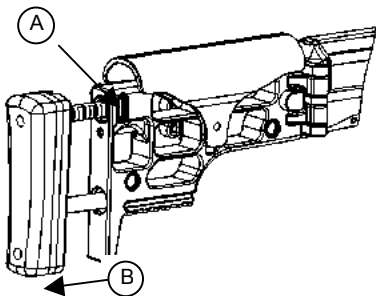
The MRAD has a folding stock for ease of transport. To fold the stock, press the folding-stock button and swing the buttstock to the ejection port side, locking it firmly into place on the bolt handle. (*Figure 12 Step A and B.*)



**Figure 12, Steps A and B.**

### Length-of-Pull Adjustment

1. To adjust the length of pull, depress the adjustment button to release the cross lock pin and slide the recoil pad to desired location. (*Figure 13, Step A and B.*)
2. After determining the correct length, release the adjustment button and allow the recoil pad to lock into place.
3. The notches on the sliding adjustment pin are in increments of .375".



**Figure 13, Steps A and B.**

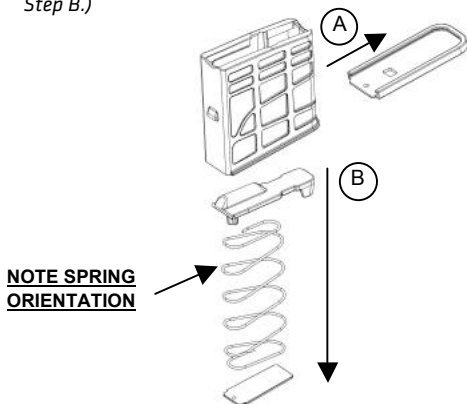
### Cheek Piece Adjustment

1. Loosen the cheek piece lock knob by turning it counterclockwise.
2. Slide the cheek piece up to a comfortable position and turn the cheek piece lock knob clockwise until secure.

### Disassembly of the Magazine Assembly

1. Depress the floor plate retainer tab on the bottom of the assembly.
2. While holding down the tab, slide the floor plate off of the magazine body. (*Figure 14, Step A.*) Be sure to hold the floor plate retainer in place because the magazine spring is under tension.

3. After removing the floor plate, slowly release the magazine spring to remove the floor plate retainer, the spring, and the follower. (Figure 14, Step B.)



**Figure 14, Step A and B.**

### **Cleaning of the Magazine Assembly**

Remove any debris by tapping the magazine or cleaning it out with cleaning brush. Wipe the entire magazine down with a cloth and ensure it is free of debris and dry. No oil or lubrication is needed in the magazine.

### **Reassembly of the Magazine Assembly**

Assembly is reverse order of disassembly. Magazine spring must be inserted according to Figure 14. Either end of spring may be placed against follower. Termination of top spring loop must face to the rear.

#### **NOTE**

Stretching springs will destroy them. Springs should NEVER be stretched.

### **Removing and Installing the Accessory Rails**

Using a T-25 Torx Wrench, remove the accessory rail screws. The rails can be installed anywhere along the 3, 6 and 9 o'clock locations on the upper receiver. The rail located at the 6 o'clock location may be used to attach the bipod assembly. When installing an accessory rail, coat the threads with 242 Loctite and torque the accessory rail screws to 35 in/lbs.

### Removal of the Barrel

Lift bolt handle to unlock bolt from barrel extension FIRST before removing barrel cross bolts. Remove the two cross bolts that pass through the barrel extension using a T-30 Torx Wrench and slide the barrel out of the receiver. (Figure 16, Step A and B.)

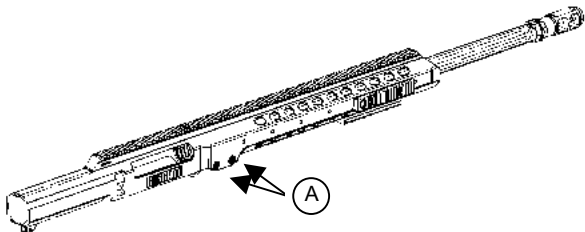


Figure 16, Step A.

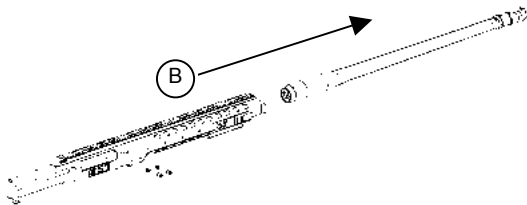


Figure 16, Step B.

#### NOTE

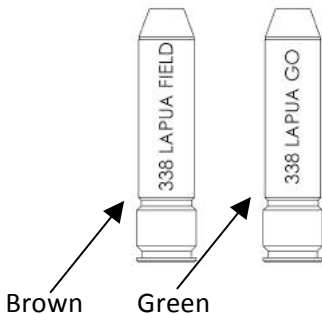
No further disassembly of the barrel assembly is recommended or necessary for maintenance.

### Installing Barrel

Barrel is installed in reverse order of removal. Care must be taken to align the barrel extension properly to receive the bolt. Insert the barrel fully into the receiver. Gently close the bolt ensuring that the bolt handle rests fully downward. Gently lift and retract bolt handle. Install two barrel screws. Torque the barrel screws to 100 in./lbs. Gently cycle the bolt fully closed and then open to ensure smooth operation.

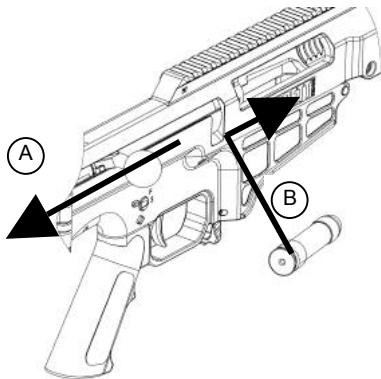
## Headspace Inspection

1. Ensure the rifle is unloaded and that the chamber is clear of obstructions. Ensure that the gages are clean before inserting.



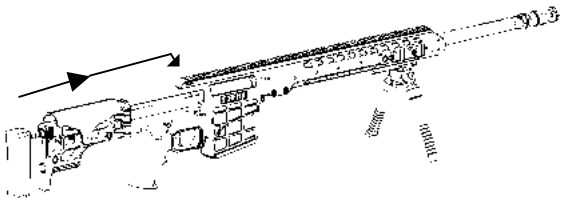
**Figure 17.**

2. Pull bolt handle backward into the open position (*Figure 18 Step A.*) and insert the Go Gage (*Figure 17.*) into the chamber. (*Figure 18, step B.*)



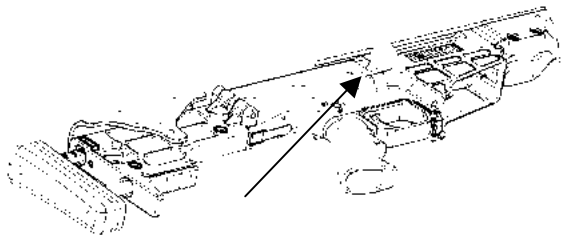
**Figure 18, Steps A and B.**

3. GENTLY slide the bolt forward and down until it stops. (Figure 19.)



**Figure 19.**

4. Turn the rifle over and inspect the location of the bolt handle. The bottom of the bolt handle should be making contact with the receiver. (Figure 20.)

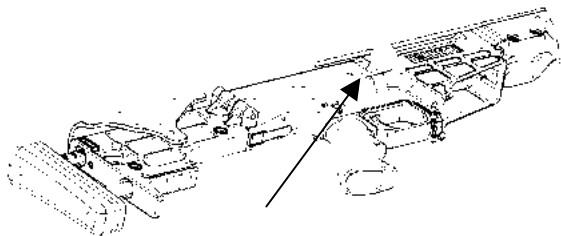


**Figure 20.**

5. Return the rifle to the upright position and slide the bolt backward to the open position. Remove the Go Gage.
6. Insert the Field Gage (Figure 17.) and GENTLY slide the bolt forward and down until it stops.

**CAUTION**  
**DO NOT FORCE THE BOLT INTO PLACE.**

7. Turn the rifle over and inspect the location of the bolt handle. The bolt handle should NOT be making contact with the receiver. If the bolt closes completely on the Field Gage, ensure the barrel is properly installed. If the bolt still closes on the Field Gage, return for repair. (Figure 21.)



**Figure 21.**

### **Caliber Conversion**

Use the disassembly method mentioned in the section titled Disassembly into Major Components to convert your rifle to a different caliber. The bolt assembly, barrel assembly and the magazine will need to be exchanged. See the section titled Removal and Disassembly of the Bolt Carrier Assembly for instruction on removing the Bolt. See the section titled "Unloading and Clearing" for instruction on removing the magazine.

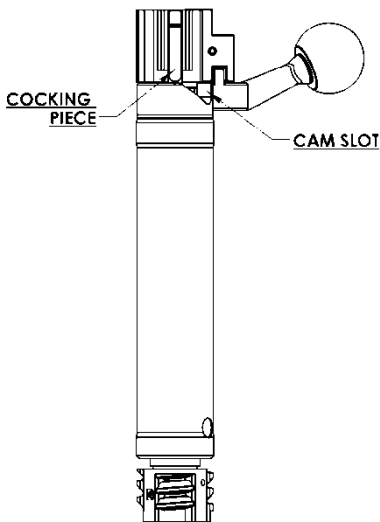


## Disassembly of the bolt carrier assembly

### NOTE

The firing-pin assembly must be cocked to enable disassembly of the bolt carrier assembly. The firing-pin assembly is cocked when the cocking piece is outside of the cam slot. (Figure 22.)

1. Lift the bolt handle to the up position. Press the receiver latch and separate the receivers. (Figures 10-11.) Withdraw the bolt carrier assembly from the back of the receiver.



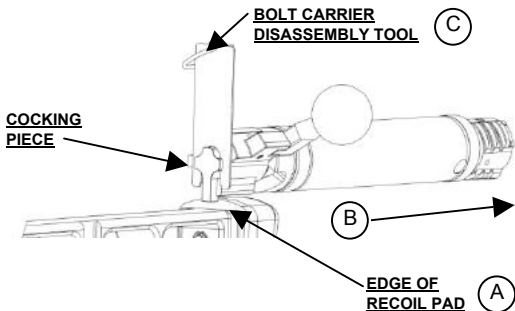
**Figure 22.**

(Cocked bolt carrier assembly)

2. Hook the face of the cocking piece on the corner or edge of non-metallic surface or use a loop of small-diameter rope such as parachute (550) cord.

It is recommended to use the hard edge of the recoil pad behind the groove on top of the buttplate assembly. (Figure 23, Step A.)

- Put pressure on the bolt carrier assembly against its spring tension in order to pull the cocking piece out enough to expose the 2 (two) disassembly slots. (Figure 23, Step B.) Only use the amount of force necessary to expose the slots in the cocking piece. Additional force could cause damage to the cocking piece or sear slot of the cocking piece shroud.
- Insert the bolt carrier disassembly tool into the two slots to retain the cocking piece in the disassembly position. (Figure 23, Step C.)

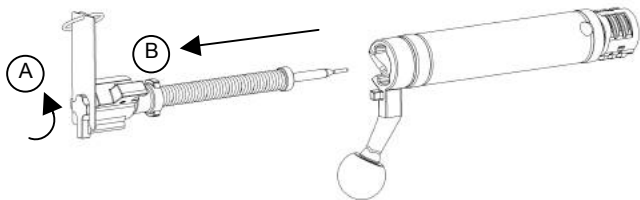


**Figure 23.**

**WARNING**

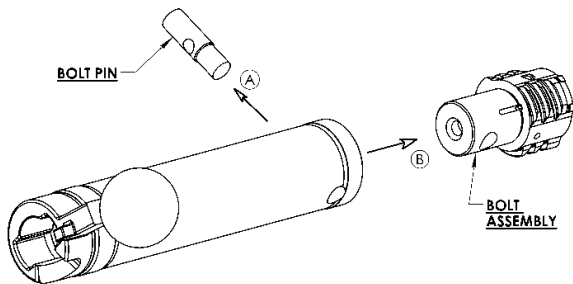
Do not remove the bolt carrier disassembly tool from the cocking piece while the firing pin assembly is removed from the bolt tube. The firing pin spring is under heavy load. Serious injury can occur if the assembly pin is removed.

- Rotate the cocking piece shroud counter clockwise about 120 degrees, or 1/3 of a turn (Figure 24, Step A.) and withdraw cocking piece (Figure 24, Step B.) from the bolt carrier.



**Figure 24.**

6. Using a punch or other pointed object, push the bolt pin (Figure 25, Step A.) out of the bolt tube. Note that the bolt pin can only be disassembled or assembled from one direction.
7. Remove the bolt assembly (Figure 25, Step B.) from the bolt carrier.



**Figure 25.**

**NOTE**

No further disassembly of the firing pin assembly is recommended or necessary for maintenance.

## Reassembly of the bolt carrier assembly

Assembly is in the reverse order of its removal. Ensure that the hole in the bolt pin is in line with the center hole of the bolt so that the firing pin can pass through.

## Disassembly and assembly of extractor

### NOTE

If the rifle fails to extract or eject, rule out other causes before attempting to remove the extractor spring or extractor. The removal of these components are for replacement only.

### Extractor removal

1. Bolt head must be removed from bolt carrier assembly before removing the extractor.
2. Locate the end of the extractor spring. It is located just behind the bolt lugs. (Figure 26.) It is a single bent wire.
3. Using a 1/16" punch, or similar pointed object, gently lift the end of the extractor spring and unwrap it counterclockwise from the bolt. With the circular part of the spring up and fully out of the slot in the bolt, withdraw the spring. (Figure 27.) Next slide the extractor out of the slot in the bolt. (Figure 28.)

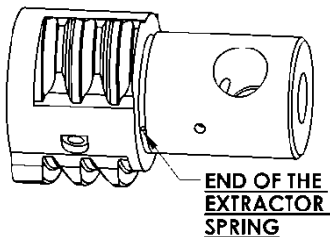
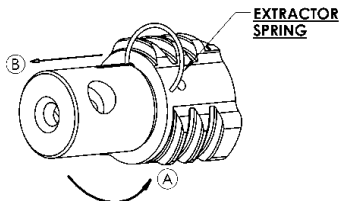
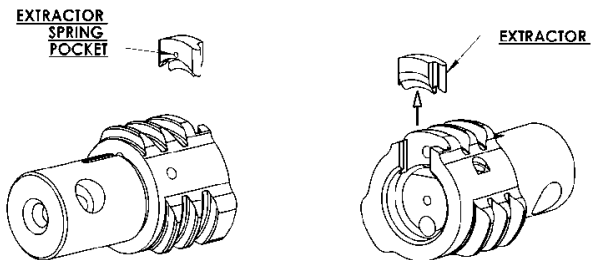


Figure 26.



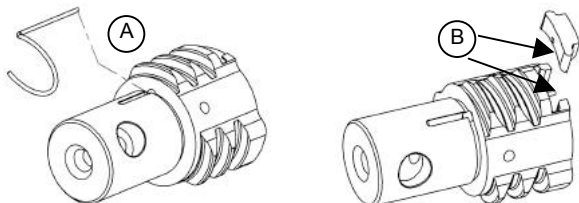
**Figure 27.**



**Figure 28.**

### **Extractor Installation**

The installation of the extractor is in reverse order of its removal. Insert the straight leg of the spring into the slot (*Figure 29, Step A.*) and wrap the circular part around the bolt. Ensure the end of the spring enters the extractor pocket. Extractor must be properly oriented where the curve of the extractor edge matched the bolt face. (*Figure 28, Step B.*)

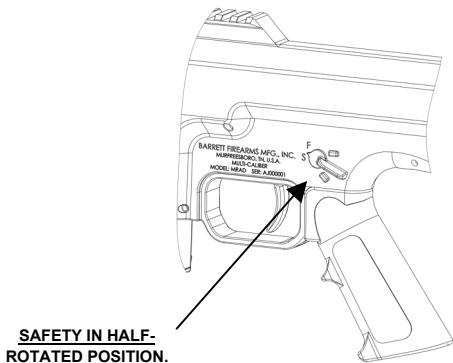


**Figure 29.**

## ADJUSTING THE TRIGGER MECHANISM

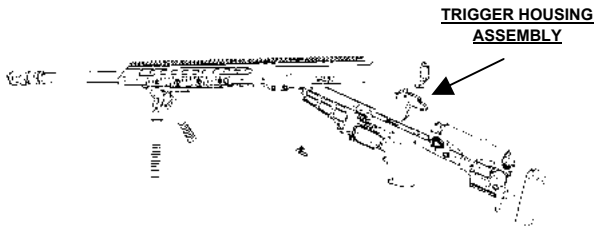
### Removal of the trigger housing assembly

1. Rotate the safety lever half way between the stops on the receiver.  
(*Figure 30.*) From the opposite side of the safety lever push and slightly rotate, back and forth, the safety out of the receiver. This may require a flat punch, cartridge point, ink pen or other similar tool.



**Figure 30.**  
(Removal of the Safety)

2. Separate the upper receiver from the lower receiver as described in the disassembly section of this manual, "Disassembly Of Major Components" (*Figure 10 and 11.*)
3. Grasp the trigger housing assembly and slide the trigger housing assembly rearward away from the magazine well opening and lift out of the receiver. (*Figure 31.*)



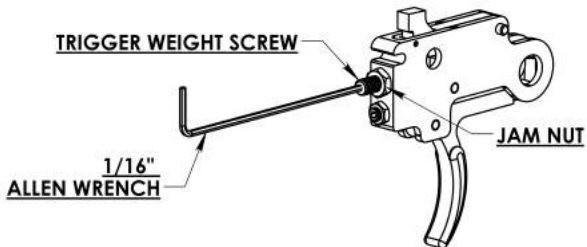
**Figure 31.**  
(Removal of the trigger housing assembly.)

### Adjusting the trigger weight

**Note**

The factory setting is 2 / 2.5 pounds.

Loosen the 5/16" jam nut on the trigger-weight screw. Using a 1/16" allen wrench turn the screw counter clockwise. The minimum setting on the trigger should not go below 1.5 pounds. This is achieved by approximately one half of a turn on the trigger-weight screw. Hold the allen wrench and do not allow the screw to move and tighten the 5/16" nut. (Figure 32.)



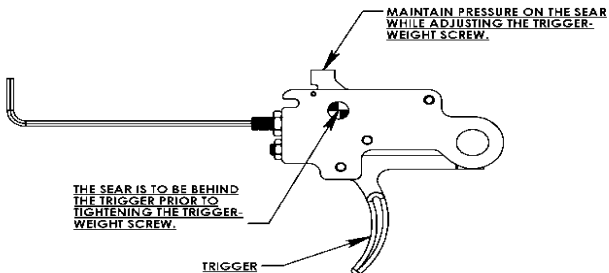
**Figure 32.**  
(Adjusting trigger weight.)

## Returning trigger weight to factory settings

### Warning

Adjusting the trigger weight too low may cause an unintentional discharge.

1. Loosen the 5/16" jam nut on the trigger-weight screw. Turn the trigger-weight screw counter clockwise approximately four turns using a 1/16" allen wrench.
2. Pull the trigger and depress the sear. (Figure 33, Step A and B.) Turn the trigger-weight screw clockwise until the plunger is fully compressed in the trigger-weight screw. Turn the trigger-weight screw counter clockwise ¼ turn and tighten the brass jam nut.



**Figure 33.**

(Returning the trigger weight to the factory setting.)

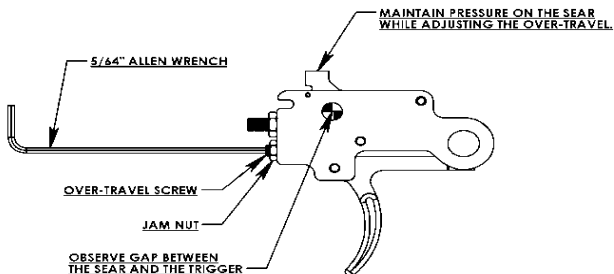


## Adjusting the trigger over travel

### NOTE

The trigger over travel is set to minimum from the factory

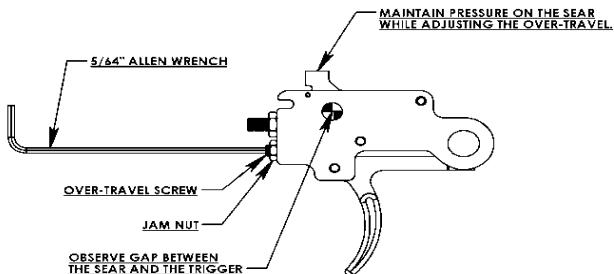
1. Loosen the  $\frac{1}{4}$ " brass jam nut. Insert a  $\frac{5}{64}$ " allen wrench into the over-travel screw.
2. Look through the hole in the side of the trigger housing and pull the trigger and press down on the sear.
3. Turn the over-travel screw counter clockwise and observe the trigger moving away from the sear.
4. Turn the screw until the desired over travel is achieved and lock into place by turning the brass jam nut clockwise until it is tight against the trigger housing. (Figure 34.)
5. Test the setting by pulling the trigger and depressing the sear. Release the trigger.
6. Slowly release the sear and ensure the trigger has enough clearance to reset.



**Figure 34.**  
(Adjusting the over travel.)

## Returning the over travel to the factory specifications

1. Loosen the  $\frac{1}{4}$ " brass jam nut. Insert a  $\frac{5}{64}$ " allen wrench into the over-travel screw.
2. Look through the hole in the side of the trigger housing and pull the trigger and press down on the sear.
3. Turn the over-travel screw counter clockwise and observe the trigger moving away from the sear.
4. Turn the screw clockwise until it locks up the trigger against the sear. Turn the over travel screw counter clockwise one quarter of a turn and lock into place by turning the brass jam nut clockwise until it is tight against the trigger housing. (Figure 35.)
5. Test the setting by pulling the trigger and depressing the sear. Release the trigger.
6. Slowly release the sear and ensure the trigger has enough clearance to reset.

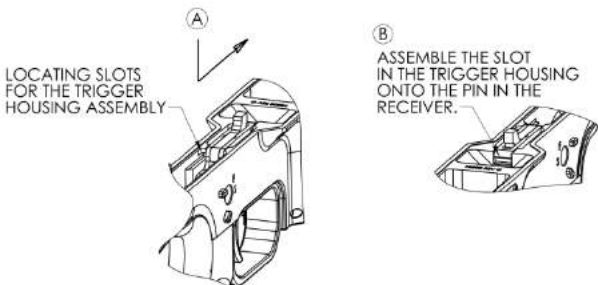


**Figure 35.**

(Resetting the over travel to the factory settings.)

## Installation of the trigger housing assembly into the receiver

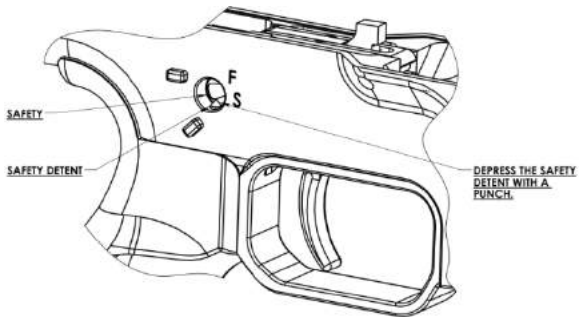
1. Insert the trigger housing assembly into the slot in the lower receiver. (*Figure 36, Step A.*) Slide the trigger housing assembly forward and align the front of the trigger housing onto the pin in the receiver. (*Figure 36, Step B.*) Next align the safety hole in the lower receiver and the hole in the trigger housing.



**Figure 36.**

(Installation of the trigger housing.)

2. Insert the safety into the receiver until it stops on the safety detent. Using the tip of a pen, cleaning rod or similar object, depress the safety detent and finish inserting the safety into the receiver. The safety lever must be halfway between the limiting stops on the lower receiver. (*Figure 37.*) The safety can be inserted on the opposite side to accommodate a left-handed shooter. Installation is the same.



**Figure 37.**  
(Installation of the safety.)

3. Ensure the bolt handle is in the up position. Close the receivers together.

### **Functional test of trigger**

#### **NOTE**

Ensure there is no live ammunition present during this test.

#### **WARNING**

Visually and physically check the chamber and make sure the rifle is not loaded.

With the rifle fully assembled, slowly cycle the action of the rifle and pull the trigger. Next, rapidly lift the bolt handle to the open position then back to closed. Pull the trigger to make sure the trigger reset. If the trigger did not reset, adjust the trigger weight to heavier poundage by repeating the above steps in the “Adjusting the trigger weight” section.

## CLEANING AND LUBRICATION

### WARNING

Unload and clear the rifle before cleaning.

### CAUTION

Always clean from the chamber towards the muzzle. Do not insert cleaning rods through the muzzle. The barrel crown could be damaged which would severely degrade the accuracy of the rifle.

### CAUTION

To protect the rifle from corrosion, the rifle and the interior of the carrying case should be moisture free before the rifle is placed in the carrying case for storage.

### Cleaning procedure

1. The rifle should be cleaned and lubricated after each shooting session. Regular cleaning prevents the corrosive effects of moisture.
2. Apply cleaning solvent to a chamber brush and clean the chamber.
3. Apply cleaning solvent to a clean cotton patch and clean the bore from the chamber to the muzzle. Repeat until patches come out clean.
4. Use a stiff plastic brush to remove carbon from both the extractor and the ejector. Depress the ejector and extractor by hand to test their smooth function.
5. Use dry patches as necessary to remove cleaner from the bore and chamber.
6. Clean the remainder of the rifle with cotton-tipped swabs, general-purpose brushes and rags. Apply light coating of preservative oil only to exposed Barrel Assembly surfaces and Bolt lugs. In extremely dirty conditions, a small amount of lubricant applied to the outside of the Bolt Carrier will allow smoother function.

## PREVENTIVE MAINTENANCE CHECKS AND SERVICES

### (Before, During and After Firing)

ITEM NO.	INTER-VAL	ITEM TO BE CHECKED	PROCEDURE	NOT READY OR AVAILABLE IF:
1	Before	MRAD	Hand cycle rifle to ensure it is functional and visually check exterior of the rifle and components for damage. Check components for cracks, breaks, and damage. Ensure all fasteners are tight. If any faults are found, notify unit maintenance.	Parts missing, loose, damaged, or broken.
2	Before	Muzzle Adapter	Check to see that the muzzle adapter is firmly secured to the barrel and that its ports are parallel to the ground when in a level shooting position.	Muzzle adapter is loose or crooked.
3	Before	Barrel Assembly	Check to ensure bore is free of obstruction. Check for excess lubrication in bore area. Swab dry.	Bore is obstructed.
4	Before	Barrel	Check headspace on barrel using "Go" and Field gages.	Bolt closes on Field gage.
5	Before	Receiver Assembly Pin	Check to see that the assembly pin is securely installed.	Pin is missing or bent.
6	Before	Magazine	Ensure that the	Free travel of

			magazine has free travel of the follower and that the magazine body is not damaged (bent or cracked).	follower is not present or magazine is damaged.
7	Before and After	Magazine	Ensure magazine is clean and dry.	Dirty or has lubricant in it.
8	During	Muzzle Adapter	Check to see that the muzzle adapter is secured to the barrel and that its ports are parallel to the ground when in a level shooting position.	Muzzle adapter is loose or crooked.
9	During	Receiver Assembly Pin	Check to see that the assembly pin is securely installed.	Pin is missing or bent.
10	During	Magazine	Ensure that the magazine has free travel of the follower and that the magazine body is not damaged (bent or cracked).	Free travel of the follower is not present or magazine is damaged.
11	After	MRAD	Hand cycle rifle to ensure it is functional and visually check exterior of the rifle and components for damage. Check components for cracks, breaks, and damage. Ensure all fasteners are tight. If any faults are	Parts missing, loose, damaged, or broken.

			found, notify unit maintenance.	
12	After	Muzzle Adapter	Check to see that the muzzle adapter is secured to the barrel and that its ports are parallel to the ground when in a level shooting position.	Muzzle adapter is loose or crooked.
13	After	Clean Barrel Bore	Clean chamber and barrel bore immediately after firing.	Chamber and/or barrel obstructed.
14	After	Barrel	Check headspace on barrel using "Go" and Field gages.	Bolt closes on Field gage
15	After	Receiver Assembly Pin	Check to see that the assembly pin is securely installed.	Pin cannot be inserted far enough to be secure.  Pin missing.
16	After	Magazine	Ensure the magazine has free travel of the follower and that the magazine body is not damaged (bent or cracked).	Free travel of follower is not present or magazine is damaged.



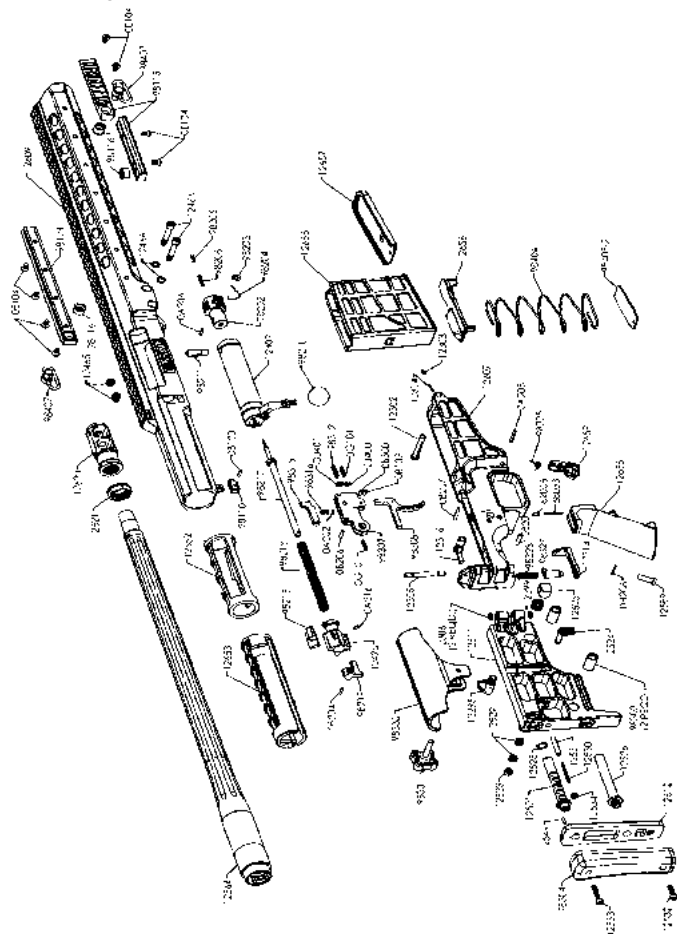
**INSPECTION OF INSTALLED ITEMS**

<b>ASSEMBLY</b>	<b>ITEM INSPECTED</b>	<b>PROCEDURE</b>	<b>CONDITION</b>
Upper Receiver Assembly	Upper Receiver Assembly	Visual inspection	Upper receiver assembly should NOT be cracked, bent or burred.
Barrel Assembly	Barrel	Visual Inspection	Barrel should be clean and free of obstruction.
Bolt Carrier Assembly	Muzzle Adapter	Visual inspection and check for looseness.	Muzzle adapter should be tight, fully screwed on and properly positioned.
Lower Receiver Assembly	Extractor and Ejector	Check spring tension and visually inspect for chips or wear.	Extractor and Ejector springs must NOT be stretched. There should be no chips and wear on the extractor.
	Firing Pin Hole	Check firing pin hole (on bolt face) for erosion/pitting.	Firing pin hole should not have erosion/pitting.
	Lower Receiver Assembly	Visual inspection.	Lower receiver assembly should NOT be cracked, bent or burred.
	Accessory Rails	Check accessory rail screws for secure installation.	Rails should be attached securely. Torque to: 35in -lbs
	Folding Stock	Check folding stock assembly pin and components.	Folding stock pin should be secure.

## TROUBLESHOOTING

MALFUNCTION	CAUSE	CORRECTIVE ACTION
Failure to chamber and lock	<ol style="list-style-type: none"> <li>1. Damaged cartridge</li> <li>2. Dirty or obstructed chamber</li> </ol>	<ol style="list-style-type: none"> <li>1. Remove and replace cartridge</li> <li>2. Clean chamber</li> </ol>
Failure to fire	<ol style="list-style-type: none"> <li>1. Faulty ammunition</li> <li>2. Cocking piece shroud not properly installed in bolt</li> <li>3. Cocking piece is dragging</li> <li>4. Firing pin or firing pin spring broken or damaged</li> <li>5. Bolt handle not down fully</li> </ol>	<ol style="list-style-type: none"> <li>1. Replace ammunition</li> <li>2. Assemble properly</li> <li>3. Clean and lubricate cocking piece</li> <li>4. Turn in for repair.</li> <li>5. Ensure bolt handle is down fully</li> </ol>
Failure to extract	<ol style="list-style-type: none"> <li>1. Broken or worn extractor</li> <li>2. Broken or worn extractor spring</li> <li>3. Extractor not moving freely</li> <li>4. Dirty ammunition or chamber</li> <li>5. Broken case rim</li> <li>6. Faulty Ammo</li> </ol>	<ol style="list-style-type: none"> <li>1. Replace extractor</li> <li>2. Replace extractor spring</li> <li>3. Clean extractor, extractor spring, and recess</li> <li>4. Clean chamber and ensure ammunition is clean</li> <li>5. Clear with cleaning rod</li> <li>6. Replace ammunition, cool if hot</li> </ol>
Failure to eject	<ol style="list-style-type: none"> <li>1. Broken or worn ejector</li> <li>2. Broken or worn ejector spring</li> <li>3. Ejector not moving freely</li> </ol>	<ol style="list-style-type: none"> <li>1. Turn in for repair</li> <li>2. Turn in for repair</li> <li>3. Turn in for repair.</li> </ol>
Very hard recoil	<ol style="list-style-type: none"> <li>1. Faulty or hot ammunition</li> <li>2. Muzzle brake missing</li> <li>3. Improper shooter position</li> <li>4. Extractor not moving freely.</li> </ol>	<ol style="list-style-type: none"> <li>1. Replace ammunition, cool if hot</li> <li>2. Turn in for repair</li> <li>3. Firmly shoulder the buttstock</li> <li>4. Ensure extractor is properly installed</li> </ol>

# MRAD EXPLODED VIEW



## MRAD PARTS LIST

PART NO.	PART NAME	QTY/RIFLE
0E104	FHCS 10-24 X .375	8
12295	FOLDING STOCK LATCH	1
12299	FOLDING STOCK SPRING	1
12302	RECEIVER ASSEMBLY PIN	1
12303	ASSEMBLY PIN PLUNGER	1
12304	ASSEMBLY PIN SPRING	1
12305	FOLDING STOCK ASSEMBLY PIN	1
12306	FOLDING STOCK BUSHING	2
12314	RECEIVER LATCH	1
12316	REVERSIBLE SAFETY	1
12409	BOLT TUBE COMPLETE	1
12464	BARREL SCREW	2
12465	KEY LOCKING THREAD INSERT	2
12466	BARREL SCREW WASHER	2
12498	COCKING PIECE SHROUD	1
12521	UPPER GUIDE ROD	1
12523	ADJUSTMENT BUTTON	1
12524	CROSS LOCK PIN	1
12525	RETAINING RING	1
12526	LOWER GUIDE ROD	1
12529	ADJUSTMENT BUTTON SPRING	2
12530	BOLT HANDLE LATCH SPRING	1
12531	BOLT HANDLE LATCH	1
12532	LOWER BUTTPAD SCREW	1
12533	UPPER BUTTPAD SCREW	1
12534	BOLT LATCH SET SCREW	1
12549	UPPER GUIDE ROD INDEX PIN	1
12564	BARREL COMPLETE	1
12589	.25-28 BUTTON HD CAP SREW	1
12607	LOWER RECEIVER	1
12609	UPPER RECEIVER	1
12611	ADJUSTABLE FOLDING STOCK	1
12612	RECOIL PAD BASE PLATE	1
12620	MUZZLE BRAKE	1
12621	MUZZLE BRAKE NUT	1
12625	FOLDING STOCK BUTTON	1
12652	FRONT BOLT GUIDE	1
12653	REAR BOLT GUIDE	1
12655	MAGAZINE	1
12656	MAGAZINE FOLLOWER	1
12657	MAGAZINE FLOOR PLATE	1
12658	PISTOL GRIP	1
12659	MAGAZINE CATCH	1
68033	SAFETY SPRING	1
82056	SAFETY DETENT	1

## MRAD Parts List Continued

PART NO.	PART NAME	QTY/RIFLE
82056	SAFETY DETENT	1
98105	BARREL EXTENSION	1
98110	RECEIVER LATCH SEAT	1
98115	LR ACCESSORY RAIL	2
98116	SLING BUSHING	3
98124	LR ACCESSORY RAIL	1
98202	BOLT	1
98203	EXTRACTOR	1
98204	EXTRACTOR SPRING	1
98205	EJECTOR	1
98206	EJECTOR SPRING	1
98210	BOLT HANDLE KNOB	1
98211	BOLT PIN	1
98215	BOLT STOP	1
98217	FIRING PIN	1
98218	FIRING PIN SPRING	1
98219	COCKING PIECE	1
98303	SLING BUSHING	2
98304	RECOIL PAD	1
98307	TRIGGER HOUSING	1
98308	TRIGGER	1
98312	TRIGGER WEIGHT SCREW	1
98315	SEAR	1
98316	SEAR SPRING	1
98325	MAGAZINE CATCH SPRING	1
98327	RECEIVER SAFETY LATCH	1
98328	RECEIVER LATCH SPRING	1
98330	CHEEK PIECE	1
98331	CHEEK PIECE LOCK KNOB	1
98404	MAGAZINE SPRING	1
98407	SLING LOOP	2
0A202	RP .062 X .375	1
0A206	RP .093 X .500	1
0A208	RP .125 X .875	1
0A216	RP .125 X .250	1
0B103	DP .125 X .375	2
0B201	DP .156 X .750	1
0B204	DP .093 X .500	1
0B206	DP .125 X .562	1
0B207	DP .125 X 1.00	1
0B300	RP .125 X .375	1
0G101	8-32 X .625 SOCKET HD SET SCREW	2
0H206	ETLW.25	1
0J400	8-32 X .25 NUT	1
0J401	10-32 X .312 NUT	1
98405-2	MAGAZINE FLOOR PLATE RETAINER	1