



INSTRUCTION MANUAL  
MANUAL DE INSTRUCCIONES  
NÁVOD NA POUŽITÍ  
BEDIENUNGSANLEITUNG  
MODE D'EMPLOI

**CZ SHADOW 2**

**Before handling the firearm read this manual carefully and observe the following safety instructions.**

Improper and careless handling of the firearm could result in accidental discharge and cause injury, death or damage to property. The same repercussions can be caused by unauthorized modifications or adjustments, corrosion, or use of non-standard or damaged ammunition. In these cases the manufacturer shall not be responsible in any manner whatsoever for the resulting consequences. Before leaving the factory the firearm was tested, inspected, and packaged in accordance with company policy. Ceska zbrojovka a.s. cannot accept responsibility for product handling whilst in transit after dispatch from the factory. Therefore, examine the firearm carefully upon receipt to ensure that it is unloaded and undamaged.

This instruction manual should always accompany the firearm in the event of loan or further sale.

## CONTENTS

SAFETY INSTRUCTIONS	2
PISTOL DESCRIPTION AND TERMINOLOGY	5
OPERATING INSTRUCTIONS	7
Ammunition	7
Removing the Magazine	7
Loading the Magazine	7
Loading of the Pistol	7
Reloading While Shooting	7
Unloading the Pistol	8
Engaging the Safety	8
Loaded Chamber Indicator	8
Sight Adjustment	9
MAINTENANCE INSTRUCTIONS	9
Stripping for Cleaning - Disassembly	9
Firing Pin Disassembly	10
Magazine Disassembly	10
Cleaning the Pistol	10
Cleaning the Barrel and the Chamber	11
Cleaning of Other Parts	11
Preserving the Pistol	11
Waste Management	11
LIST OF PARTS	12
TROUBLESHOOTING, CAUSES AND REMEDIES	13
TECHNICAL SPECIFICATIONS	14
LIST OF ILLUSTRATIONS	14

**SAFETY INSTRUCTIONS**

Always follow the safety instructions for your safety and the safety of others.

1. Always handle your firearm as if it were loaded.
2. Never point your firearm at anything you do not intend to shoot at. Also never point a firearm at anybody even in fun.
3. Never take anyone's word that the firearm is unloaded.
4. Always make sure that the firearm is not loaded before laying it down or handing it over to another person.
5. Always store or carry your firearm empty, with the striking mechanism forward except when you intend to shoot.
6. Never abuse the firearm by using it for any purposes other than shooting.
7. Never leave a firearm unattended.
8. Prior to loading the firearm ensure the barrel, chamber, and action are clean and clear of obstructions. If the firearm becomes excessively dirty during firing clean it immediately. Always clean the firearm after use.
9. Do not shoot the pistol, unless you are certain about the ammunition you are using. Do not use unmarked or hand-loaded ammunition from an unknown source, ammunition with a cracked, deformed or dented case or with a damaged bullet. Reloading is an expert activity and incorrectly reloaded ammunition may be extremely dangerous. It may result in heavy damage or destruction of the pistol and serious injury or death of the shooter or other persons. Always use clean and dry original high quality commercially manufactured ammunition, which corresponds to the caliber of the firearm.
10. Never drink alcohol or take drugs before and during shooting.
11. Whenever practical always wear safety glasses and ear protection while shooting.
12. Always keep the safety applied when the pistol is loaded with a cartridge in the chamber, until you are ready to fire. Keep the firearm pointed in a safe direction when disengaging the safety.
13. Always keep the ejection port clear of obstructions and people.
14. Never pull the trigger or put your finger within the trigger guard unless you are aiming at a target and ready to fire.
15. Always make absolutely sure of your target and the area behind it before pulling the trigger. The bullet can pass through or past the target up to several hundred meters.
16. Never shoot at a hard surface such as rock, or a liquid surface such as water.
17. Never fire near an animal unless it is trained to withstand the noise.
18. Never indulge in "horseplay" while holding the firearm.
19. Failure to fire: In case it fails to fire, hold the firearm keeping it pointed in a safe direction and wait 30 seconds. If a hangfire (slow ignition) has occurred, the cartridge will fire within 30 seconds. If the cartridge does not fire, eject the cartridge and examine it. If the firing pin indent on the cartridge is light, or non-existent, have the firearm examined by a competent gunsmith.
20. Always make sure the firearm is not loaded before cleaning, storing or travelling. Remove any unused ammunition from the pistol and store it in compliance with the law.

21. Always keep and store your firearm and ammunition in separate secure locations out of reach and sight of children and unauthorized people. Always protect the ammunition from sources of heat and open fire.
22. Never alter any parts of your firearm; the safety and proper function of your firearm could be seriously affected.
23. Always be aware that corrosion, use of damaged ammunition, dropping the firearm on hard surfaces or other "rough treatment" can cause damage that is not necessarily obvious at first sight. If something like this happens, have the firearm examined and tested by a competent gunsmith.

## RULES OF THE SAFE HANDLING TRITIUM SIGHTS



Tritium sights for CZ pistols involve a luminous front sight (tritium radiator of 0,55 GBq activity) and a luminous rear sight (2 tritium radiators of 0,55444 GBq activity) that is installed at the pistol by means of precision dovetails. Tritium in the gaseous state (99% HT and 1% HTO) is enclosed in plastic ampoules with a luminescent element and these ampoules are fixed by glue into the metallic cap of the sight so that the manipulation and storage of the sights is not exposed to any risks. The sights are marked as H3 (radioactive tritium).

The third generation of the sights retains all the advantageous features of the preceding generation of sights and several improvements are added:

- built-in shock absorber
- solid protective bushing providing less sensitivity against rough manipulation
- immovable window for a better light output with additional protection against a damage
- tolerance against longer immersion in currently used solvents and cleaning agents
- guaranteed continuous available light intensity for the period of 12 years
- sealing design protects the sights against an accidental damage, avoids the unwanted manipulation with the light source, inhibits to penetrate the dirt into the visual system and to hide the light
- provided a finer transition between the aiming during the day and the night
- simple installation (no modification of the arm is necessary)
- no added weight nor size
- no maintenance
- no battery needed (no losses of the energy at the cold weather)

**Safety instructions in case of the sights damage**

In regular conditions of the storage, use and maintenance there is no risk to the user caused by emitted ionizing radiation, because it doesn't penetrate metallic caps, in which the ampoules with radiators are fixed. In case of a nearly unreal incidental damage of all ampoules in one set at the moment, when the arm is in shooting position (position of the sights closer to the shooter), the single effective radiation dose wouldn't exceed the value of 0,26 mSv. What does this value present? It is for example:

- 1/12 of the dose which is received by an ordinary inhabitant in course of a year due to the natural radioactive background (3,5 mSv / year)
- less than 1/4 of the general effective dose limit to an ordinary inhabitant

**Recommended first aid at the inspiration of the gaseous tritium**

The gaseous tritium state is practically inactive and causes a slight internal contamination. In case of its inspiration it is recommended to increase the intake of liquids and eventually to take some diuretic (beer with low content of alcohol) for acceleration of the body water exchange.

**DUTIES OF THE TRITIUM SIGHTS OWNER**

1. The sights are a radioactive radiator in the period of 6,5 years since their purchase according to the Czech Republic legislation.
2. At the purchase the owner obtains a guide with rules of the safe handling and a document on the impermeability of the radionuclidic radiators in the set (certificate of the encased radionuclidic radiator), which must be preserved and presented on request of the competent authority.
3. When handling a type approved product, which is the source of the ionizing radiation, it is necessary to respect national regulations for protection against the ionizing radiation (the appropriate national legislation).
4. In case of the ownership of more than 9 sets of sights (the total activity exceeding 10 GBq) the owner is obliged to consult the duties resulting from the appropriate national legislation at the competent authority.
5. To avoid such manipulation, when a rough mechanical damage of the sights may happen.
6. It is not allowed to carry out any changes, relating to the properties of the protection against the radiation.
7. In case of the destruction or the damage, the sights mustn't be further used. The owner is obliged to secure safely the device changed in such a way and to pass it to the distributor or the manufacturer for the safe liquidation. The same procedure to be applied for liquidation of no more used sights.
8. The manipulation with sights is governed by general principles of the protection against the ionizing radiation. At the current use there are no requested tests of impermeability during the service life of the sights.

The sights were type approved by the decision of the competent authority Ref. No. SÚJB/RCAB/9960/2014.

20.4.2016  
Státní úřad pro jadernou bezpečnost  
Regionální centrum Praha  
Bartošková 28  
140 00 Praha 4

## PISTOL DESCRIPTION AND TERMINOLOGY

The names of basic pistol parts used in this Instruction Manual are presented in Fig. 1 on the inner side of the left-hand cover. Nomenclature of all CZ SHADOW 2 parts are presented in the section *List of Parts*.

Designed particularly for sports shooting up to 50 metres, the CZ SHADOW 2 pistol is a semi automatic handgun equipped with locked breech. It is provided with double action trigger mechanism (SA/DA), hammer safety notch and an ambidextrous manual safety. Characteristic features of all versions are:

- A universal handgun for both left and right handed people
- Selective SA/DA firing mechanism operation
- Large capacity double-column magazine
- Comfortable grip and balance in either hand
- Good results at instinctive shooting (without aiming)
- Low trigger pull weight
- The trigger overtravel is defined by means of a distance screw (it is pre-set by the manufacturer)
- High accuracy of fire
- Long service life
- High reliability, even with various types of cartridges
- The slide stays open after the last cartridge has been fired
- Suitable for Combat shooting
- The sights comprise of a fiber optic front sight and height-adjustable rear sight, on special request tritium or micrometrical sights can be installed
- The front part of the frame is equipped with mounting rails (MIL-STD-1913) which serve for the purpose of the attachment of special accessories

Each pistol is supplied with these items:

- 3 pieces of magazines (the number of magazines can differ for particular versions of the pistol)
- maintenance and cleaning instruments (cleaning brush, cleaning rod, key for trigger adjustment and sights securement, polymer case)
- documents related to the pistol (instruction manual, CD containing promotion files and instruction manuals in various languages, warranty certificate/card, grouping paper)
- padlock (only in selected versions)

Versions	Operation	Manual Safety	Safety Stop on Hammer	Loaded Chamber Indicator
CZ SHADOW 2	SA/DA	yes	yes	*
CZ 75 SP-01 SHADOW	SA/DA	yes	yes	*
CZ 75 SP-01 SHADOW LINE	SA/DA	yes	yes	*
CZ 75 SHADOW LINE	SA/DA	yes	yes	*
CZ 75 COMPACT SHADOW LINE	SA/DA	yes	yes	*

\* Loaded chamber indicator supplied on special order only

Comments:

*SA (Single Action)*

The trigger mechanism operates in a single action mode of fire. The hammer is cocked manually and then after pressing the trigger the pistol is fired. The trigger travel is short, and pull weight is low. After each discharge the hammer remains cocked.

*DA (Double Action)*

The trigger mechanism operates in a double action mode of fire. The hammer is cocked, released and the pistol fired by one pull of the trigger. The trigger travel is longer, and trigger pull weight is higher than at SA mode of fire.

*Safety Stop on the Hammer*

A half-cock safety notch is on the hammer so as to prevent it from striking the firing pin when the hammer is manually cocked, and a thumb possibly slips. When the hammer hits the safety stop, it is not touching the firing pin stop, but its position is set back.

## OPERATING INSTRUCTIONS

### Ammunition

Always use ammunition in an allowable production design which is in compliance with standards applicable for ammunition manufacturers and is approved by the CIP (Permanent International Commission for Firearms Testing) or SAAMI (Sporting Arms and Ammunition Manufacturers' Institute Inc. of the United States). The use of other cartridges could damage the handgun or cause injury to the shooter. When using factory-made ammunition with standard speed, the use of firearms produced by Česká zbrojovka a.s. is safe. Check the ammunition you are going to use to make sure that it corresponds to the caliber of your firearm. Commercially produced ammunition is clearly marked with the caliber on the bottom or around the bottom of each cartridge case.

### Removing the Magazine

Grip the pistol in your right or left hand and depress the magazine catch located by the thumb or middle finger (Fig. 2). The magazine disengages and falls out of the frame. This pistol model is equipped with the user type magazine catch which can be reversed by gunsmith for the right or left hand operation.

### Loading the Magazine

With the open end uppermost, grasp the magazine in one hand. Place a cartridge on the magazine follower. Press the cartridge down and back until it touches the rear edge of the magazine. Place the next cartridge on top of the previous cartridge and press down and back as previously described. We recommend that when some cartridges are loaded in the magazine, depress them slightly with the thumb of the hand which holds the magazine.

The number of cartridges can be checked through the inspection holes in the sides of the magazine. Do not try to exceed the magazine capacity - doing so can cause a feeding failure.

### Loading of the Pistol

**ALWAYS MAKE SURE THE PISTOL IS POINTED IN A SAFE DIRECTION WHEN LOADING!**

Insert a loaded magazine and ensure that it has engaged the magazine catch properly.

Hold the pistol by the grip with one hand, and with the thumb and index finger grasp the serrated finger grips on both sides of the slide. Retract the slide to the stop and allow it to snap forward (Fig. 3). This procedure cocks the hammer and inserts a cartridge into the chamber. The pistol is now ready to fire. If you do not intend to fire immediately ensure the pistol safety by one of the methods mentioned in the section: *Engaging the Safety Mode*.

### Reloading While Shooting

When the last cartridge has been fired the slide will stay to the rear. Remove the empty magazine and replace it with a loaded one. Depress with the thumb the slide stop with the shooting hand (Fig. 4), or retract the slide with the other hand and allow it to snap forward (Fig. 3). The pistol is again loaded and ready to fire.



### Unloading the Pistol

ALWAYS MAKE SURE THE PISTOL IS POINTED IN A SAFE DIRECTION!

- Remove the magazine
- Retract the slide and verify the last cartridge has been extracted from the chamber and ejected
- Let the slide snap fully forward
- Depress the trigger (dry fire)

### Engaging the Safety

Push the safety up to the Safety-On position (Fig. 5) until the red warning dot is covered. The safety in this position blocks the trigger mechanism and slide, thus preventing the pulling of the trigger and operating the slide.

Since the trigger mechanism has been specifically adjusted, it is possible to move the safety onto the "SAFE" position even if the hammer is placed on the safety notch. In this case, however, it is strongly not recommended to engage the safety because the trigger mechanism might be damaged when cocking the hammer by force or pulling the trigger. If damage to the trigger mechanism occurs, let it be repaired by a certified gunsmith.

Besides the method previously described it is possible to put the pistol into a safety mode and still be ready to fire immediately:

Load the pistol. Grasp the grip, POINT IN A SAFE DIRECTION. With a thumb press on the grooved area (thumb piece) of the hammer, pull the trigger and release the hammer slowly forward (Fig. 6) until it rests on the action or safety notch of the hammer. Release the trigger. Practise this operation very carefully to avoid an accidental discharge! We strongly recommend to practise this operation beforehand with the pistol unloaded!

In this state the pistol is safe for all normal handling and at the same time ready for immediate use.

Please remember that the safest way to secure a pistol is to unload it and store it in a safe place!

### Loaded Chamber Indicator

The protrusion of the loaded chamber indicator above the top surface of the slide indicates a cartridge loaded in the cartridge chamber (supplied on special order only). This protrusion can be checked both by sight and by touch.

## Sight Adjustment

The pistol sights were zeroed in at the factory at a distance of 25 m so that the mean point of impact approximately conforms to the point of aim.

The windage can be corrected by shifting the rear sight within the dovetail. Prior to the adjustment it is necessary to loosen the screw securing the rear sight against falling out. Once the rear sight has been adjusted it is necessary to tighten the screw again and secure it with the application of the Loctite 243. Elevation can be corrected by turning the screw.

In case of a requirement, there is an option to exchange the usual rear sights for another sight of a suitable type, or as the case may be to also exchange the front sight, which is secured by a roll pin. These adjustments should be entrusted to a competent gunsmith.

## MAINTENANCE INSTRUCTIONS

### Stripping for Cleaning - Disassembly

POINT YOUR PISTOL IN A SAFE DIRECTION!

1. Remove the magazine. The pistol must not be disassembled with the magazine inserted!
2. Put the safety to the "OFF" position, in order to release the movement of the slide.
3. MAKE SURE THAT THERE IS NO CARTRIDGE IN THE CHAMBER!
4. Retract the hammer slightly back and then release it, until it stops on the half-cock (safety) notch position. In this state the handling which follows will be easier.
5. Put your left thumb through the trigger guard and with the other hand grasp the forward part of the slide firmly (Fig. 7). Push the slide slightly back until the two vertical lines on the rear part of the frame and slide are in line with each other.
6. KEEPING THE LINES ALIGNED push (tap) the slide stop from the right hand side of the weapon, e.g. using the magazine base (Fig. 8). Remove the slide stop from the left.
7. Pull the slide and the barrel forward off the frame.
8. Remove the recoil spring and guide and finally the barrel.

No further disassembly is needed for routine maintenance. When a great number of cartridges has been fired, it is advisable to also disassemble the firing pin and magazine.

**Firing Pin Disassembly**

Push in the rear end of firing pin using a suitable tool, below the level of the firing pin stop, and press the firing pin stop approximately 2 mm down. Then cover the firing pin stop with your thumb in order not to lose the spring-loaded firing pin, and with the other hand pull the firing pin stop completely out of the slide. Be very careful at this stage of the disassembly procedure, as the firing pin is spring-loaded and could fly out, getting lost, or even causing injury.

**Magazine Disassembly**

Move the magazine base lock to the disassembly position (Fig. 9) or, in case of a different design, push on the magazine base lock through a hole in the base. Move the magazine base approx. 5 mm forward. Cover the base with your thumb to prevent losing the magazine spring and with the other hand take off the base from its guiding rails. Be careful during the disassembly as the spring could fly out, or even cause an injury.

**CAUTION:**

No further disassembly of your pistol is recommended. Should your pistol require adjustment or repair be sure the task is entrusted to a competent gunsmith!

**Cleaning the Pistol**

Clean the pistol

- Each time you use it
- If you get your pistol wet
- As soon as possible after shooting
- At least once a year in a temperate climate
- As often as once a month in a tropical climate, or other demanding environments

**Cleaning the Barrel and the Chamber**

If the pistol has not been fired or if only a few cartridges have been fired, clean the barrel and chamber with a clean patch attached to the cleaning rod. Repeat the cleaning, changing patches, until the last patch comes out clean.

When the barrel is very dirty, apply a gun cleaning solution using a cleaning brush. Let the solvent act for about 10 minutes (this time may vary depending on the solvent agent being used). Then thoroughly scrub out the barrel. Subsequently, dry the barrel and chamber with a clean patch and check that all powder residues or fouling have been removed. If necessary repeat this procedure.

The cleaning rod and the brush must be inserted into the barrel from the chamber, to prevent wear or damage to the muzzle. Pass the brush all the way through the barrel before reversing the movement. If you try to change directions with the brush in the barrel, the brush could stick.

**Cleaning of Other Parts**

Other parts of the pistol (including the external surfaces of the barrel) can be cleaned with a dry cloth, old toothbrush, brass bristle brush or a wooden scraper. Preserving oil or paraffin oil can be used for proper cleaning. Never use an agent designed for barrel cleaning. These solutions could remain in the joints, and after some time could cause corrosion.

Check that cloth particles or brush bristles have not become lodged in any part of the pistol.

**Preserving the Pistol**

When the barrel, chamber, and all accessible parts are clean and dry, wipe these parts with a cloth soaked in gun oil or apply the oil in spray form. Remove all excess oil.

Before shooting always pull through the barrel with a dry patch. At very low temperatures remove the oil from all accessible parts or apply a lubricant especially for these conditions.

Use thick preserving agents such as preserving grease only for long-term storage in severe climatic environments, and remove it thoroughly before use from all parts of the firearm.

**Waste Management**

When used properly, the materials used in the product and its packaging have no adverse effects on human health or the environment. When disposing of the product or its packaging, metal parts (steel and non-ferrous metals), plastics, wood, paper and cardboard should be stored separately in collecting containers intended specifically for that purpose.

## LIST OF PARTS

1	Frame *	29	Safety - Left *
2	Slide Stop *	30	Safety Detent Plunger - Left
3	Slide Stop Spring	31	Safety Detent Plunger Spring *
4	Slide Stop Spring Pin	32	Magazine Catch
5	Trigger *	33	Magazine Catch Spring
6	Trigger Pin	34	Trigger Bar Spring
7	Trigger Bar	35	Magazine Catch Spring Screw
8	Trigger Spring	36	Magazine *
9	Pin (3x)	37	Firing Pin *
10	Ejector	38	Firing Pin Spring
11	Sear	39	Firing Pin Stop *
12	Sear Spring	40	Buffer *
13	Sear Pin	41	Recoil Spring *
14	Safety - Right *	42	Recoil Spring Guide *
15	Safety Detent Plunger - Right *	43	Barrel *
16	Hammer *	44	Slide *
17	Disconnecter	45	Front Sight
18	Hammer Pin	46	Front Sight Pin
19	Hammer Pin Retaining Peg	47	Loaded Chamber Indicator *
20	Main Spring Strut *	48	Loaded Chamber Indicator Spring *
21	Main Spring	49	Loaded Chamber Indicator Nut *
22	Main Spring Plug *	50	Extractor *
23	Main Spring Plug Pin	51	Extractor Pin
24	Magazine Guide *	52	Extractor Spring
25	Magazine Guide Pin	53	Rear Sight *
26	Grip Panel - Left *	54	Securing Screw (2x) *
27	Grip Panel - Right *	55	Trigger Screw *
28	Grip Panel Screw (2x) *	56	Shaped Washer (2x) *

Comments:

The parts marked \* differ according to versions, or as case may be in some versions are entirely missing.

## TROUBLESHOOTING, CAUSES AND REMEDIES

If your pistol is properly used and maintained, malfunctions will rarely occur. However, if such a situation does occur, please observe the following instructions.

**CAUTION** - If a malfunction occurs, the possibility of an accidental discharge is substantially higher. For this reason, when clearing malfunctions, follow the above mentioned *Safety Instructions*. Keep the pistol pointed in a safe direction, do not turn the pistol against your body or anyone else's! Do not place your hands in front of the barrel!

Malfunction	Possible Cause	Remedy
A cartridge has not been fed into the chamber or the slide has not fully locked with the barrel	Magazine is not fully inserted or is damaged. The pistol or cartridges are fouled (dirty) or too heavily greased.	Insert magazine properly or change magazine. Clean the pistol and cartridges and wipe them dry or as the situation dictates, slightly lubricate.
Misfire	Defective cartridge.  Firing pin hole is fouled (dirty) or improper lubricant was used in low temperature conditions.	Pull the trigger again. If a discharge is not initiated, follow the Safety Instructions according to point 19.  Disassemble and clean the firing pin or use a low temperature lubricant.
A shot sounds "weak" combined with failure to eject the cartridge case	The cartridge has been activated but no powder load was inside the cartridge case.	Unload the pistol and check that the bullet has not obstructed the barrel. Any subsequent shot could cause damage to the barrel.
The spent case has not been ejected	Chamber, extractor or ammunition are dirty, or unsuitable lubricant was used in low temperatures.	Clean and wipe the pistol dry or eventually lubricate lightly with a suitable agent. Use new and clean ammunition.

If you are not able to clear the malfunction in the manner described above, entrust the pistol to a competent gunsmith for inspection and repair.

The Company, reserves the right to make any changes it thinks necessary to improve its models or to meet any requirements of manufacturing or commercial nature.

## TECHNICAL SPECIFICATIONS

Model	CZ SHADOW 2	CZ 75 SP-01 SHADOW	CZ 75 SP-01 SHADOW LINE	CZ 75 SHADOW LINE	CZ 75 COMPACT SHADOW LINE
Caliber	9x19	9x19 9x21	9x19	9x19	9x19
Overall length [mm]	217±2	209	209	209	183
Height [mm]	157	150	146	146	139
Width [mm]	34±1	42	34	34	35
Weight with empty magazine [g]	max. 1330	1170	1170	1170	815
Frame	Steel	Steel	Steel	Steel	Light Alloy
Barrel length (without glide ramp) [mm]	119	114/119	114	114	92,5
Sight radius [mm]	168±1	163	163	163	143
Magazine capacity * [cartridges]	19*	18/10*	17	17/16	14

\* For some countries, the pistols are supplied with a reduced magazine capacity in compliance with local laws.

## LIST OF ILLUSTRATIONS

1. The names of basic parts
2. Magazine removal
3. Pistol loading
4. Slide release from its "rear lock-up" position by depressing slide stop
5. Shifting the safety to the "SAFETY-ON" position
6. Release of the hammer to its forward position
7. Positioning of the slide during disassembly
8. Slide stop removal using the magazine base to facilitate this operation
9. Magazine disassembly

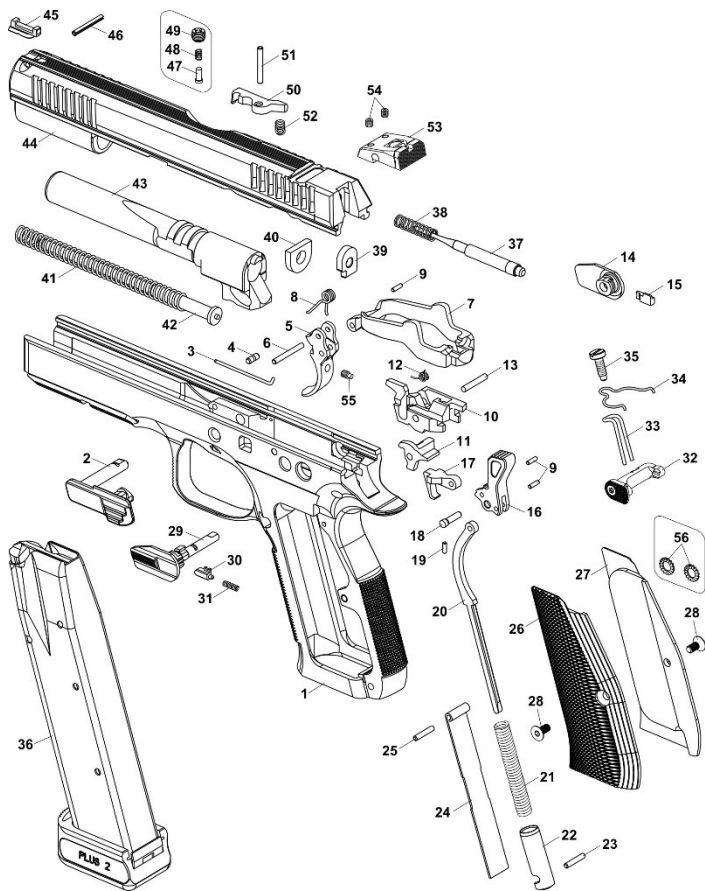



1

## CZ SHADOW 2



2



3



4



5



6



7



8



9

