



**FN HERSTAL**

**OWNER'S MANUAL**

**FS2000 Carbine  
Cal. 5.56 x 45 mm NATO**

## NEW GUN OWNER'S RECORD

Model : .....

Serial number (\*) : .....

Date of purchase : .....

Purchased from : .....

Purchase price : .....

(\*) The serial number of your carbine has been engraved on the left side of the frame.

The descriptions and illustrations in this Owner's Manual may differ slightly from the present configuration of the product. This would reflect the constant evolution of the product during its industrial life.

Data in this manual is technical only and of no contractual value.

### Caution :

This manual has been written exclusively for the FN HERSTAL FS2000 carbine.

Warnings and instructions are different for each type of gun.

If your FN HERSTAL carbine has an inscription other than «FN HERSTAL BELGIUM FS2000 cal. 5.56 x 45» on the rear left side of the frame or if the external appearance of the carbine does not correspond to the illustrations of this manual, you must contact your dealer/departmental armorer or write us immediately to obtain the free Owner's Manual that has been written specifically for your carbine.



FNH USA, LLC  
PO Box 697  
McLean, VA 22101

703-288-1292  
[www.FNHUSA.com](http://www.FNHUSA.com)

## Foreword

We are pleased that you have purchased a semi-automatic FN HERSTAL FS2000 carbine.

The easy-to-use and fully ambidextrous FS2000 carbine stands for consistent performance and functional design and provides the operating precision and safety expected from a FN HERSTAL carbine.



*The carbine complies with the latest technical evolutions in firearm design for law enforcement and sporting use and has been manufactured from space-age corrosion-resistant materials.*

*It has been conceived based on the experience of a whole team of experts in every field related to carbines.*

The innovative design is focused on firing and carrying comfort. With a reasonable amount of care, your FN HERSTAL FS2000 should give you many years of dependable, enjoyable service.

In order to take maximum advantage of the many features of your FN HERSTAL FS2000 carbine, regularly review this Owner's Manual.

Please feel free to write us if you have any observation or question regarding the performance or the operation of your carbine.

Thank you

### **Safety and warranty notes**

*Like all firearms, the FN HERSTAL FS2000 carbine, if handled in a careless or reckless manner, can be very dangerous.*

*For that reason, the carbine has been sold under the express understanding that FN HERSTAL declines any responsibility and invalidates any guarantee and liability claims for incidental or consequential damages (injuries, loss of use of property, commercial loss, loss of earnings and profits,...) resulting in whole or partly from :*

- *a discharge with criminal intent or through negligence*
- *improper or careless handling*
- *unauthorized servicing*
- *the modification or the alteration of the basic carbine design*
- *the use of non-original parts*
- *the alteration of the safety devices*
- *the use of incorrect "arms & ammunition" combinations*
- *the use of defective, damaged, unsafe, ..., ammunitions*
- *the use of reloaded ammunition*
- *an inadequate care of the carbine (e.g. corrosion, damage,...)*
- *a disregard of malfunctions*
- *a resale in contradiction to legislation*
- *other circumstances beyond our direct and immediate control*

*FN HERSTAL reserves the right to refuse servicing a carbine which has been modified (removal of metal from the barrel, modifications of the firing mechanism and/or other parts,...) and will, in such a case, always recommend to restore the carbine to its original specifications. Parts and labor required for*

## **TABLE OF CONTENTS**

<b>1. Safety information .....</b>	<b>6</b>
<b>2. Technical information .....</b>	<b>12</b>
2.1. Nomenclature .....	12
2.2. Description .....	14
2.3. Technical data .....	15
2.4. Functioning .....	16
<b>3. Contents of the storage box .....</b>	<b>19</b>
<b>4. Using the carbine .....</b>	<b>20</b>
4.1. Safety checks .....	20
4.2. Loading the magazine .....	22
4.3. Loading and charging the carbine .....	23
4.3.1. Loading the carbine .....	23
4.3.2. Charging the carbine .....	23
4.4. Firing the carbine .....	24
4.5. Unloading the carbine .....	25
4.6. Adjustment of the back-up sight .....	28
4.7. Installation of a sling (accessory) .....	29
4.8. Installation of the safety rod .....	30
4.9. Installation of the safety lock .....	31

<b>5. Field stripping .....</b>	<b>32</b>
5.1. Disassembly of the carbine .....	32
5.1.1. Safety checks and cocking the hammer .....	32
5.1.2. Barrel receiver .....	32
5.1.3. Bolt and bolt carrier assembly .....	33
5.1.4. Gas plug and piston .....	34
5.1.5. Hammer group assembly .....	36
5.2. Complementary disassembly .....	37
5.2.1. Extractor .....	37
5.2.2. Handguard .....	37
5.2.3. Magazines .....	38
5.3. Complementary reassembly .....	40
5.3.1. Extractor .....	40
5.3.2. Handguard .....	40
5.3.3. Magazines .....	41
5.4. Reassembly of the carbine .....	43
5.4.1. Hammer group assembly .....	43
5.4.2. Gas plug and piston .....	44
5.4.3. Bolt and bolt carrier assembly .....	45
5.4.4. Barrel receiver .....	48

<b>6. Cleaning and lubrication .....</b>	<b>50</b>
6.1. Lubricant and solvents specifications .....	51
6.2. Cleaning and lubrication tools .....	51
6.2.1. Tool and combination scraper OREA 892 .....	51
6.3. Cleaning and lubrication before firing .....	52
6.4. Cleaning and lubrication after firing .....	54
6.4.1. Barrel receiver .....	54
6.4.2. Bolt and bolt carrier assembly .....	55
6.4.3. Hammer group assembly .....	56
6.4.4. Frame and handguard .....	57
6.4.5. Magazine .....	57
<b>7. Taking care of the carbine.....</b>	<b>58</b>
<b>8. Troubleshooting .....</b>	<b>59</b>
8.1. Immediate actions .....	59
<b>9. Accessories .....</b>	<b>60</b>

## 1. SAFETY INFORMATION

As a carbine owner, you accept a set of demanding responsibilities. How you take these responsibilities can mean the difference between life and death.

There is no excuse for careless or abusive handling of any firearm. At all times, handle your FS2000 and any other firearm with intense respect for its power and potential danger.

**Read and understand the cautions and proper handling procedures outlined in this booklet before using your new firearm.**

- ✓ Always keep the muzzle of your carbine pointed in a safe direction.

*Never point any firearm at anything you do not intend to shoot. Be extremely alert and aware of all persons and property within the range of your ammunition.*

- ✓ Never rely totally on your firearm's mechanical «safety» devices.

*Always assume that your carbine can be fired at any time, even with all safety mechanisms engaged.*

*The fire selector is the only apparent external safety device of the FS2000 carbine : when this fire selector is at the position 'S' (SAFETY), it is impossible to operate the trigger.*

*The FS2000 carbine has also several passive safety mechanisms that enhance safety.*

*As with other carbines, you must always treat your FS2000 as ready-to-fire, and only load a round and cock the carbine when shooting is imminent.*

*Like any mechanical device, a «safety» can sometimes fail; it can be jarred or inadvertently manipulated into an unsafe condition.*

*Mechanical «safeties» merely aid safe gun handling and are no excuse for pointing your carbine's muzzle in an unsafe direction.*

*Safe gun handling does not stop with your carbine's mechanical «safety» devices : it starts there. Always treat this carbine with the respect due to a loaded, ready-to-fire carbine.*

✔ **Avoid carrying your FS2000 with a round in the chamber.**

*For good safety practice, it is recommended that a round is not chambered until immediately before you will fire the carbine.*

*If it is nevertheless necessary to carry the FS2000 with a round in the chamber, set the fire selector at the position 'S' (SAFETY).*

*For law enforcement personnel, refer to the procedures of your department on carrying a loaded carbine with a round in the chamber.*

✔ **Whenever you handle your FS2000, or hand it to someone, make sure it is completely unloaded.**

*To fully unload your FS2000, proceed as described in § 4.5.*

*It is vital that, when unloading, you remove the magazine from your carbine so that a round is not automatically chambered when releasing the charging handle.*

*Always keep the chamber and bolt empty unless shooting is imminent.*

✔ **Do not transport your carbine loaded.**

*Keep it unloaded, whether carried on a sling, in a gun carrying bag or another kind of container.*

*For law enforcement personnel, refer to the procedures of your department on carrying a loaded carbine.*

✔ **Beware of barrel obstructions.**

*When preparing to shoot your carbine, check for a barrel obstruction as follows : first fully unload the carbine as described in § 4.5.*

*Be certain no live round is in the chamber !*

*Then glance down the barrel to be sure it is clear of any obstruction. It takes only a small obstruction to dangerously increase pressures. Before the first firing, clean the bore with a cleaning rod and rag, and wipe away any anti-rust compounds in the chamber and around the breech block.*

✔ **Be alert to the signs of ammunition malfunction.**

*If you detect an off sound or light recoil when a round is fired, fully unload the carbine as described in § 4.5.*

*With the charging handle pulled and held rearwards and the chamber empty, glance down the barrel to make sure that an obstruction does not remain in the barrel.*

*If there is an obstruction, completely clear the barrel before loading and firing again.*

*Failure to follow these instructions can cause extensive damage to your carbine and possible serious injury to yourself and others.*

## 1. SAFETY INFORMATION (CONTINUED)

- ✔ Be certain your carbine is completely unloaded before cleaning.

*Because so many gun accidents occur when a firearm is being cleaned, special and extreme care should be taken to be sure your carbine is unloaded before disassembly, cleaning and reassembly.*

*Keep ammunition away from the cleaning location. Never test the mechanical function of any firearm with live ammunition.*

- ✔ Always completely unload your carbine when not in use.

*Your responsibilities do not end when your firearm is unattended. Store your carbine and ammunition separately and well beyond the reach of children.*

*Take all safeguards to ensure that your carbine does not become available to untrained, inexperienced or unwelcome hands.*

*At all times, comply with the local and state laws.*

*For law enforcement personnel, refer to the procedures of your department on storing your carbine.*

- ✔ Make sure of adequate ventilation in the area that you discharge a firearm. Wash hands thoroughly after exposure to ammunition or cleaning a firearm.

*Lead exposure can be obtained from discharging firearms in poorly ventilated areas, cleaning firearms or handling ammunition. Lead is a substance that has been known to cause birth defects, reproductive harm and other serious injury.*

- ✔ Use the proper ammunition.

*The barrel and the bolt of this carbine have been made with substantial safety margins over the pressures developed by the 5.56 x 45 mm NATO ammunition.*

*However, FN HERSTAL assumes no liability for accidents which occur through the use of rounds of different caliber or not manufactured according to the SAAMI or NATO standards.*

*FN HERSTAL cannot assume any responsibility for the use of unsafe or improper arms and ammunition combinations. It is your responsibility to read and heed all warnings in this Owner's Manual and on ammunition boxes.*

- ✔ Examine every round you put in your FS2000 carbine.

*Your FS2000 carbine is designed and chambered for 5.56 x 45 mm NATO ammunitions. The chambering for your carbine is printed clearly on the left side of the frame.*

*Failure to use correct ammunition may result in serious injury to yourself or others.*



- ✓ Before dry-firing, visually and physically check if the chamber is empty.
- ✓ Treat every carbine with the respect due to a loaded gun, even though you are certain the gun is unloaded !
- ✓ Keep your fingers away from the trigger while unloading, loading and removing the magazine.

*Only touch the trigger when you are ready to shoot.*

- ✓ Be sure of your target and backstop.

*Take additional care during low light periods. Know the range of your ammunition. Never shoot at water or hard objects.*

- ✓ Dropping your FS2000 or any other gun when loaded can cause an accidental discharge.

*Although the FS2000 carbine has been provided with a special safety device to prevent firing when it is accidentally dropped on its flash-hider (even when it is cocked), be extremely careful, like with any other firearm, to avoid dropping the carbine.*

- ✓ Always set the fire selector at the position 'S' (SAFETY) before crossing a fence, climbing a tree, jumping a ditch or negotiating other obstacles with a loaded and/or cocked carbine.

*Never place your carbine on a car or on any unstable object.*

*For law enforcement personnel, refer to the procedures of your department.*

- ✓ If your FS2000 fails to fire, keep the muzzle pointed in a safe direction.

*Hold this position for a minimum of 30 seconds. Put the fire selector on 'SAFE' and then remove the magazine. Carefully pull the charging handle rearwards and remove the round.*

*If the primer is indented, the round should be disposed of in a way that it can not cause harm.*

*If the primer is not indented, completely unload the carbine. Your carbine should be examined by a qualified gunsmith/ your departmental armorer and the cause of the malfunction should be corrected before further use.*

## 1. SAFETY INFORMATION (CONTINUED)

- ✔ Wear eye and ear protection when shooting.

*Unprotected, repeated exposure to gunfire can cause hearing damage. Wear ear protectors (shooting earplugs or muffs) to guard against such damage.*

*Wear shooting glasses to protect your eyes from flying particles. Always keep a safe distance between the muzzle of your firearm and any persons nearby, as muzzle blast, debris and ejecting shells could inflict serious injury.*

*Also, wear eye protection when disassembling and cleaning your carbine to prevent the possibility of springs, spring-tensioned parts, solvents or other agents from contacting your eyes.*

- ✔ Be defensive and on guard against unsafe handling around you and others.

*Do not be timid when it comes to gun safety. If you observe other shooters violating any of these safety precautions, politely suggest safer handling practices.*

- ✔ Supervise and teach firearms safety to all members of your family.

*This is especially important when children and non-shooters are involved. Closely supervise newcomers to the shooting sports. Encourage enrollment in shooting safety courses.*

- ✔ Never drink alcoholic beverages or take any type of drugs before or during shooting.

*Your vision and judgement could be dangerously impaired, making your carbine handling unsafe to you or to others.*

- ✔ Periodic maintenance : avoid unauthorized servicing.

*Your FS2000 is a mechanical device which will not last forever, and as such, is subject to wear and requires periodic inspection, adjustment and service. Like all FN HERSTAL firearms, your carbine should be serviced by a FN HERSTAL Recommended Service Center.*

*FN HERSTAL cannot assume any responsibility for injuries suffered or caused by unauthorized servicing, alterations or modifications of FN HERSTAL firearms.*

- ✔ FN HERSTAL reserves the right to refuse service on firearms that have been altered, added to or substantially changed.

*Removal of metal from the barrel or modifications of the firing mechanism and/or operating parts may lead to FN HERSTAL's refusal of service on such firearms. FN HERSTAL will charge the owner for parts and labor to return the firearm to original FN HERSTAL specifications.*

**Read and heed all warnings in this Owner's Manual, on ammunition boxes and with all accessories that you install on your firearm.**

**It is your responsibility to secure the most up-to-date information on the safe handling procedures for your FN HERSTAL FS2000 Carbine.**

**FN HERSTAL assumes no liability for incidents which occur when unsafe or improper gun accessories or ammunition combinations are used.**

**It can be very dangerous to alter firing mechanism parts of this or any firearm.**

**BE CAREFUL !**

## 2. TECHNICAL INFORMATION

### 2.1. Nomenclature



Right hand view



Left hand view

## 2.2. Description

The FN Herstal FS2000 is a bullpup integrated weapon system. Its outer shape has been designed with rounded contours without any protruding parts even when equipped with accessories. The innovative design is focused on firing and carrying comfort.

The FN Herstal FS2000 is fully ambidextrous without any modification due to the forward ejection. The fire selector, the magazine release button and the charging handle are easily reachable by either hand.

The basic caliber of the FN Herstal FS2000 is the 5.56 x 45 mm standard ammunition.

Any standard sighting system can be fixed on the upper MIL-STD-1913 Picatinny rail at the appropriate eye relief. The FN Herstal FS2000 is provided with back-up adjustable sights.

The standard handguard can be replaced by accessories such as a tri-rail handguard, a laser designator, a flashlight... Any configuration of the FN Herstal FS2000 respects the original ergonomics of the firearm. The natural balance and the carrying comfort are never downgraded.

The FN Herstal FS2000 carbine features one firing mode : semi-automatic.

## 2.3. Technical data

### Functional data

Operating principle :	Gas operated, rotating bolt
Caliber :	5.56 x 45 mm NATO
Firing mode :	Semi-automatic
Magazine :	M16 type
Magazine capacity :	10 rounds or 30 rounds
Barrel length :	17.4" (443 mm)
Number of grooves :	6
Twist and direction :	7" (180 mm) right hand
Ejection :	Forwards
Safety :	Manual safety : locking of the trigger.
	Locking safety : firing impossible as long as the bolt is not locked.
	Drop safety : automatic locking of the hammer.

### Dimensions and weight

Overall length :	29.1" (740 mm)
Width :	3.2" (80 mm)
Height :	10.2" (259 mm)
Weight :	7.6 lb (3.450 kg) (without magazine) 7.94 lb (3.606 kg) (with empty 10-round magazine) 7.86 lb (3.567 kg) (with empty 30-round magazine)

### Ballistics

The following data apply to FS2000 carbine firing  
5.56 x 45 mm ammunition.

Muzzle velocity :	2985 ft/s (910 m/s)
Effective range :	546.8 yd (500 m)
Safety range :	3280 yd (3000 m)

### Sight

Back-up sights :

- front sight : adjustable in elevation
- rear sight : foldable and adjustable in windage

Interface for sight :

10" (254 mm)-length Picatinny rail (MIL-STD-1913).

## 2.4. Functioning

### Composition

The FS2000 carbine consists of the following assemblies and components :

- The barrel receiver group

*The barrel receiver is located on the top of the front part of the frame. It consists of the barrel, its support and the Picatinny rail (MIL-STD-1913).*
- The frame group

*The frame group consists of a polymer frame onto which the fire selector and the trigger have been installed.*
- The handguard group

*The handguard group is located under the front of the frame.*
- The bolt and bolt carrier group

*The bolt and bolt carrier group is located inside the frame. The bolt and bolt carrier group converts the recoil energy generated when firing a round into kinetic energy necessary for the operation of the carbine.*
- The hammer group

*The hammer group is located inside the frame. The hammer group controls the firing operation of the firearm.*
- The magazine

*The magazine is inserted into the bottom of the frame.*
- The flash hider plug

*The flash hider plug can be fitted onto the flash hider in order to protect the barrel.*



## Ejection towards the front

- After extraction of the case, this one remains held on the bolt by the extractor.
- So the case follows the bolt during its backward moving and a part of its forward moving (in opposite to usual systems where ejection follows extraction).
- During the forward moving of the bolt and bolt carrier (bolt and slide pushed forwards under the force of the spring, return), the release unit raises the extractor which releases the case.
- The case is then propelled into the switch by the action of the ejector.
- During the following of the forward moving of the bolt and bolt carrier, the switch is raised and pushes the case into the ejection tube.
- The case is then propelled through the case anti-return and is pushed by the bolt alignment lever.
- The case continues going forwards and goes out of the weapon by the ejection opening door located on the front right side of the weapon.

## Safety features

- The fire selector is the only apparent external safety device of the FS2000 carbine.

The operation of the FS2000 carbine depends on the setting of the fire selector featuring 2 positions :

➤ The position **'S' (SAFETY)**

When the fire selector is set at this position, it is impossible to operate the trigger.

➤ The position **'1' (SEMI-AUTOMATIC)**

When the fire selector is set at this position, the carbine fires semi-automatically on the condition that the carbine has been loaded and cocked as described in § 4.3, one shot will be fired for each trigger pull.

- The hammer is blocked and the firing pin can not protrude until the bolt carrier has reached its most forward position.
- The primary sear is automatically locked if the carbine is dropped.

## 2.4. Functioning (continued)

### Magazines

2 types of magazine are available : a 10-round magazine and a 30-round magazine.

Each FS2000 carbine has been designed to be fitted only with one type of magazine.

Some states limit the magazine capacity to 10 rounds.

All FS2000 sold in those states will be shipped with magazines with reduced total magazine capacity in compliance with the current state law.

*The illustrations below show a 10-round and a 30-round magazine : make sure you have verified the capacity of your magazine before installing it onto your carbine.*

10-round Magazine



30-round Magazine



### Ammunition

The FS2000 carbine should only be used with 5.56 x 45 mm ammunition.

*This is indicated on the left side of the frame.*

**The barrel and the bolt of the FS2000 carbine have been made with substantial safety margins in order to be able to cope with pressures developed by the 5.56 x 45 mm NATO ammunition.**

**Nevertheless, FN HERSTAL cannot assume any responsibility for incidents which result from the use of rounds of different caliber or not fabricated according to the SAAMI or NATO standards.**

**EXAMINE EACH ROUND BEFORE YOU PUT IT IN YOUR CARBINE !**

## Gas plug

The FS2000 is equipped with a gas plug which is a regulator featuring 2 positions :

- 'Normal' position (12 o'clock)  
*This position corresponds to the 'standard ammunition'.*
- 'Adverse condition' position (2 o'clock)  
*This position corresponds to the 'lower pressure ammunition'.*

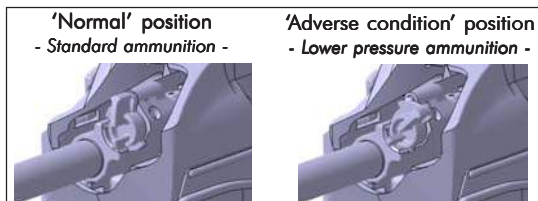

### CAUTION

The 'normal' position should always be used except if the ammunitions used are too weak to ensure a correct semi-automatic operating of the weapon.

Using the 'adverse condition' position is then advised.

Take care that, in case of a not appropriate using of this position, the bump of the bolt carrier at the back is stronger and the parts life and the firer's comfort are reduced.

## 3. CONTENTS OF THE STORAGE BOX

The FS2000 carbine is supplied in a storage box.

The storage box contains the following items :

- A FS2000 carbine;
- A 30-round magazine;  
*The magazine capacity is reduced to 10 rounds if required by the current state law.*
- An Owner's Manual;
- A safety lock and 2 keys;
- A safety rod;
- Some tools needed for field stripping and setting the carbine :
  - A wrench, front sight OREA 255,
  - A tool and combination scraper OREA 892,
  - A tool for adjusting sight screw OREA 893.
- An user maintenance kit (optional) composed of :
  - A cleaning handle, complete OREA 271/1,
  - A cleaning brush assembly OREA 184,
  - A chamber cleaning brush assembly OREA 258,
  - A cleaning brush OREA 895,
  - An oil can OREA 700.

## 4. USING THE CARBINE

### 4.1. Safety checks

- Keep carbine pointed in a safe direction.
- Set the fire selector to the position 'S' (SAFETY).
- If the magazine is still present into the carbine, press the magazine release button and remove the magazine out of the carbine pulling it downwards.
- Pull the charging handle completely rearwards and release it.

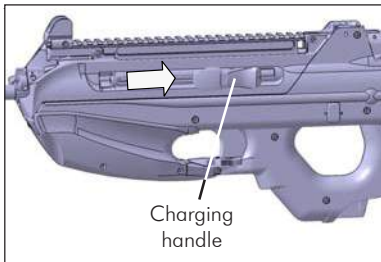

- Pull the charging handle completely rearwards and then push it upwards to lock it at its rear position.

***When taking its place into the locking notch, the charging handle has a short back movement to the front.***

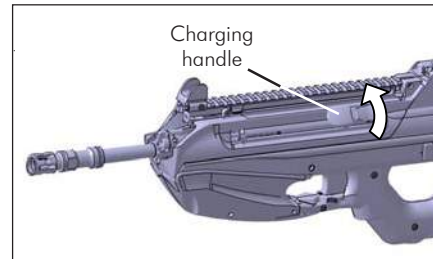

- Raise the inspection cover.

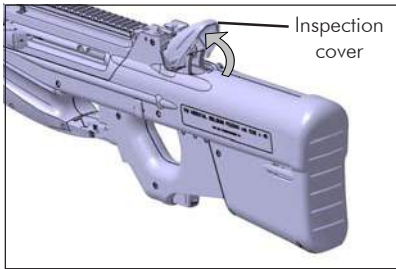

- Looking through the opening of the inspection cover, check that the carbine is empty (chamber and bolt).
- Push down the charging handle to unlock it and let it moving to the front.
- Point the carbine in a safe direction and set the fire selector to the position '1' (**SEMI-AUTOMATIC**).
- Press the trigger to release the hammer.
- Set the fire selector to the position 'S' (**SAFETY**).

- Close the inspection cover.
- Close the ejection opening door.
- Be sure to initially clean the carbine before use.

#### **CAUTION**

Leaving the protective lubricant in the firearm can cause a stoppage, malfunction or failure due to over pressure.

#### **WARNING**

Ensure that only ammunition of proper caliber and good condition is used. When disassembled, inspect all parts for excessive wear or serviceability. If any doubt, show it to your dealer / department armorer for confirmation and replacement if necessary

## 4.2. Loading the magazine

- Carry out the safety checks as described in § 4.1.
- If the magazine is still in the carbine, (1) press the magazine release button and (2) remove the magazine out of the carbine by pulling it downwards.

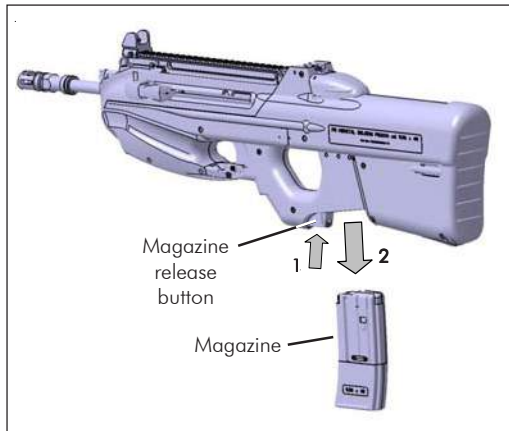

- Fill the magazine by inserting cartridges as follows :
  - Keep the magazine orientating its feed lips upwards.
  - Using thumb, push the cartridges, one by one, into the magazine.



### CAUTION

The magazine has a maximum capacity of 10 cartridges (or 30 cartridges according to the current state law)  
Never try to load more than 10 cartridges (or 30 cartridges) into the magazine.

### 4.3. Loading and charging the carbine

#### CAUTION

The safety checks should have been carried out.  
The carbine should have been correctly  
cleaned and lubricated.

#### 4.3.1. Loading the carbine

- Set the fire selector to the position 'S' (SAFETY).

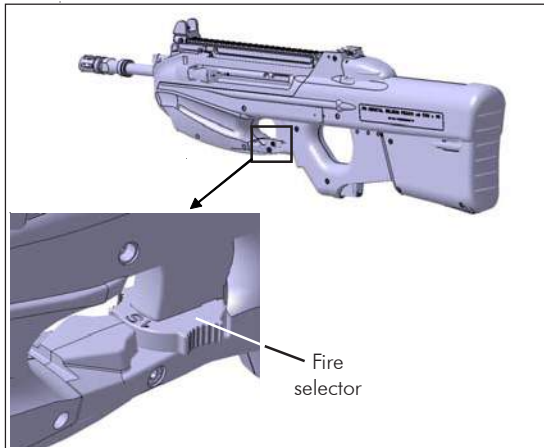

- Install a loaded magazine into the carbine by pushing on its bottom.
- Ensure the magazine is locked by pulling it downwards.



#### 4.3.2. Charging the carbine

- Pull the charging handle completely rearwards and then release it.

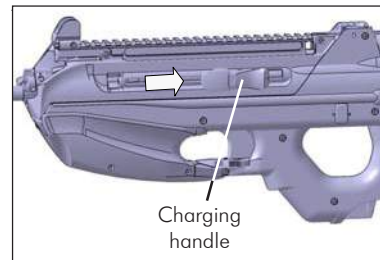

*This causes the hammer to be cocked and the first cartridge to be chambered.*

**Never hold back the charging handle during its forward motion.**

## 4.4. Firing the carbine

- Raise the rear sight (if no other sight installed).

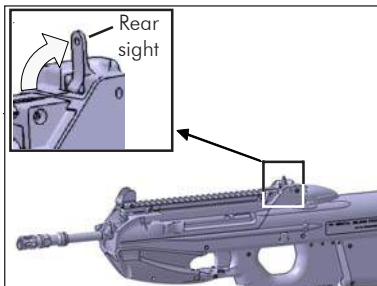

- Aim the carbine at the target.
- Check if the position of the gas plug correspond to the ammunitions used (see § 2.4).

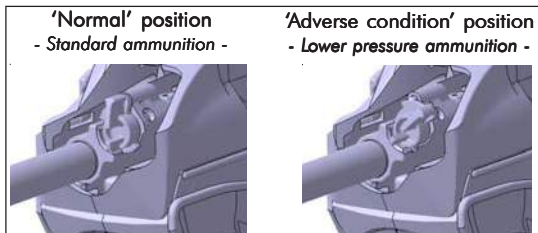

- Set the fire selector to the position '1' (SEMI-AUTOMATIC).

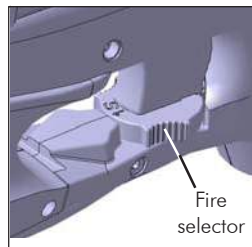

- Pull the trigger : one shot will be fired for each trigger pull.

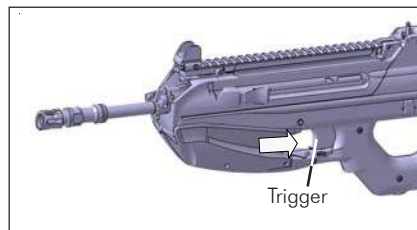

*After one or several rounds the ejection opening door will automatically be opened by the cases.*



## 4.5. Unloading the carbine

- Keep the carbine pointed in a safe direction.
- Set the fire selector to the position 'S' (SAFETY).
- (1) Press the magazine release button and (2) remove the magazine out of the carbine pulling it downwards.

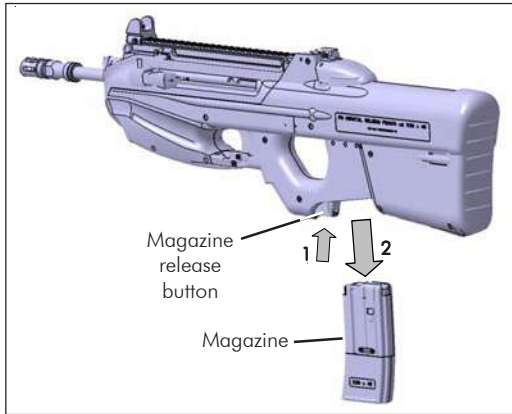

- If needed, unload the magazine.

- Pull the charging handle completely rearwards.

*After having been pulled, the charging handle will then move freely to the front.*

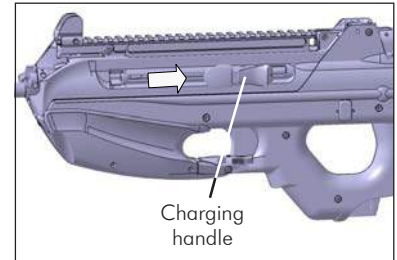

*If a cartridge or a case was in the chamber it will be ejected through the ejection tube and will go out by the ejection opening door.*

*If necessary, open the ejection opening door and point the barrel downwards.*

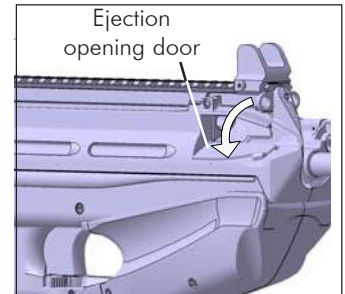

## 4.5. Unloading the carbine (continued)

- Pull the charging handle completely rearwards and then push it upwards to lock it at its rear position.

*When taking its place into the locking notch, the charging handle has a short back movement to the front.*

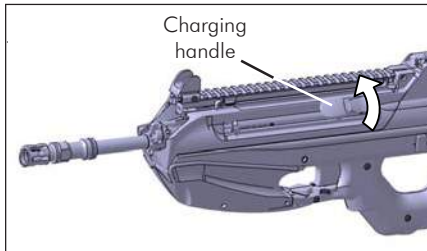

- Raise the inspection cover.

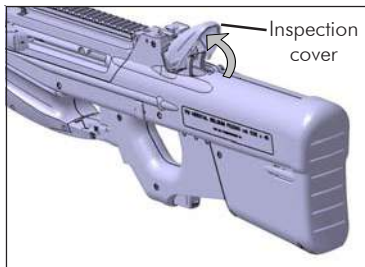

- Looking through the opening of the inspection cover, check that the carbine is empty (chamber and bolt).
- Push down the charging handle to unlock it and let it moving to the front.

*This handling brings the bolt and bolt carrier assembly back to the front and release the tension of the return spring.*

- Point the carbine in a safe direction and set the fire selector to the position '1' (SEMI-AUTOMATIC).

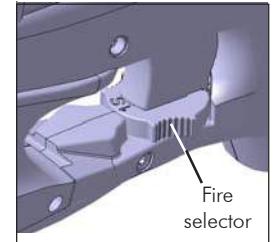

- Press the trigger to release the hammer.

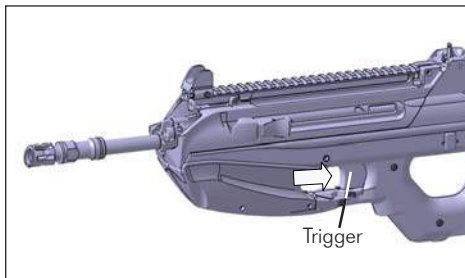

- Close the ejection opening door.

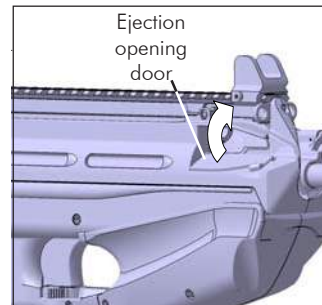

- Set the fire selector to the position 'S' (SAFETY).

- Close the inspection cover.



## 4.6. Adjustment of the back-up sight

- If adjustment of the Mean Point of Impact (MPI) for windage is required, using the OREA 893, turn the square head of the rear sight screw by 1/4 of turn.

*In order to move the MPI towards the right side, turn the rear sight screw in the clockwise direction.*

*In order to move the MPI towards the left side, turn the rear sight screw in the counterclockwise direction .*

*Each 1/4 of turn will change the lateral position of the MPI by 2.25 cm on a target localised at 50 m.*

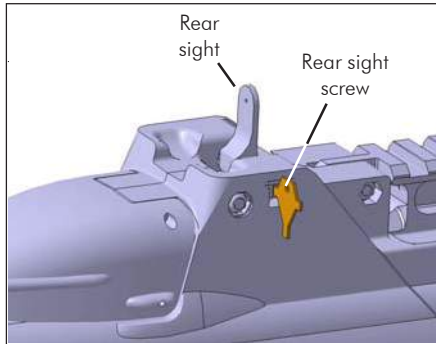

- If adjusting elevation is required, using the tool OREA 255, turn the front sight.

*In order to raise the MPI, turn the front sight in the counterclockwise direction.*

*In order to lower the MPI, turn the front sight in the clockwise direction.*

*Each 1/4 of turn will change the vertical position of the MPI by 4.5 cm on a target localised at 50 m.*

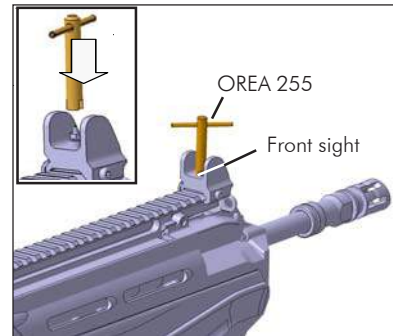

## 4.7. Installation of a sling (accessory)

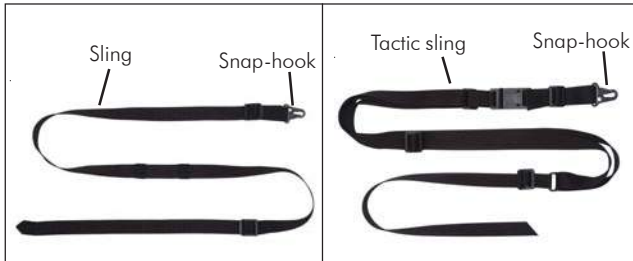

- Position the rear of the sling at the left side of the frame with the buckle facing the frame.
- Pass the rear of the sling from the top of the frame through the slot on one side of the frame, under the carbine and up through the slot on the other side of the frame. Pass then the rear of the sling through the buckle.

***Do not tighten the sling around the frame.***

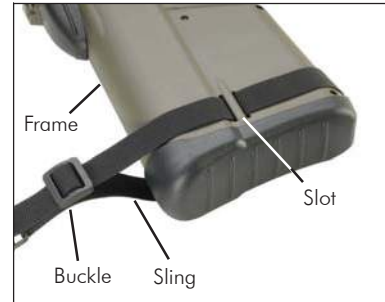

- Hook the snap-hook of the sling in the sling swivel.

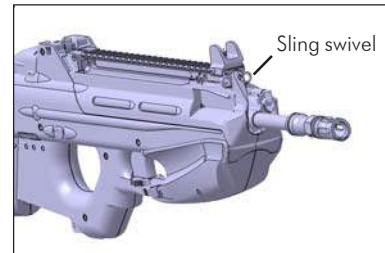

## 4.8. Installation of the safety rod

- If not already done, carry out the safety checks as described in § 4.1.
- Pull the charging handle completely rearwards.

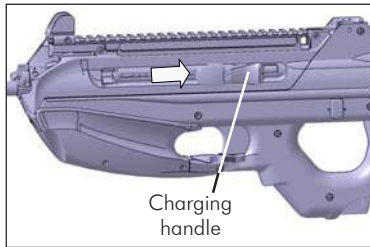

- Push the charging handle upwards to lock it at its rear position.

***When taking its place into the locking notch, the charging handle has a short back movement to the front.***

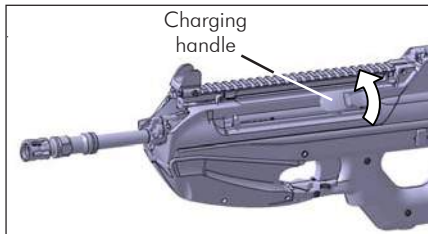

- From the bottom of the housing of the magazine, position the smaller tip of the safety rod into the chamber.



- Push down the charging handle to release it and let it moving to the front.
- Raising the inspection cover, check if the safety rod is correctly positioned into the chamber.

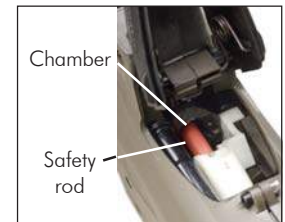

## 4.9. Installation of the safety lock

- If not already done, carry out the safety checks as described in § 4.1.
- Pull the charging handle completely rearwards.

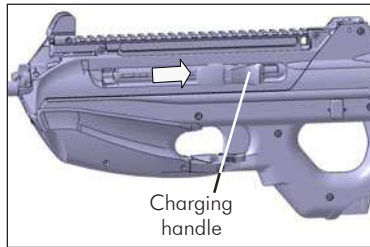

- Push the charging handle upwards to lock it at its rear position.

***When taking its place into the locking notch, the charging handle has a short back movement to the front.***

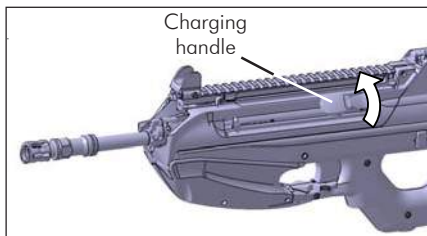

- Raise the inspection cover.
- Install the safety lock onto the frame taking care to position its middle part against the basis of the inspection cover.



- Lock the safety lock.
- Push down the charging handle to release it and let it moving to the front.

## 5. FIELD STRIPPING

Before any intervention on the FS2000 carbine, ensure to be familiar with the safety information given in Chapter 1 of this Owner's Manual.

### WARNING

Wear eye protection and safety shoes when disassembling and reassembling the carbine to protect you from any injury.

### 5.1. Disassembly of the carbine

#### 5.1.1. Safety checks and cocking the hammer

- Carry out the safety checks (see § 4.1).

- Pull the charging handle completely rearwards.

*After having been pulled, the charging handle will then move freely to the front.*

**The hammer is then cocked to allow the removal of the hammer group assembly (see below).**

#### 5.1.2. Barrel receiver

### WARNING

After firing, the barrel can be hot.

- Push the stripping pin located at the right side of the carbine.

*The stripping pin will then go out at the left side of the carbine.*

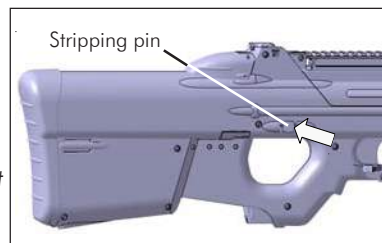

- Pull the stripping pin at the left side of the carbine until it goes no further.
- Remove the barrel receiver out of the frame by pushing it forwards.

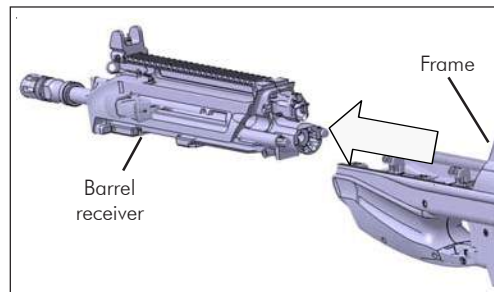



### 5.1.3. Bolt and bolt carrier assembly

- Remove the bolt and bolt carrier assembly out of the frame (1) by sliding it forwards and then (2) pulling it upwards.

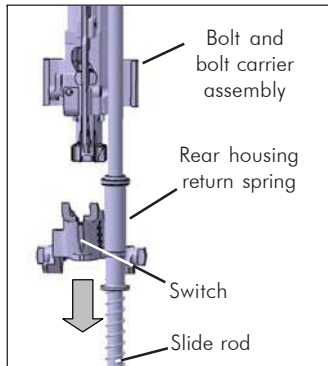
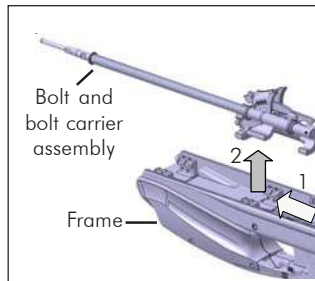

- Position the bolt and bolt carrier assembly vertically by supporting it on the tip of the slide rod. Slide the rear housing return spring downwards to release the switch from the bolt and bolt carrier assembly.

### CAUTION

Pay attention not to pince your fingers between the switch and the bolt if the rear housing return spring has been inadvertently released.

- (1) Slightly raise the firing pin retaining plunger located on the upper part of the bolt and bolt carrier assembly and (2) pull the firing pin out of the slide body.

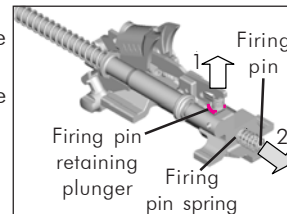

**The captured firing pin spring must be attached to the firing pin at all times.**

**The captured firing pin spring should not be removed or replaced at anytime except by an authorized armorer or FNH USA Warranty and Repair Service Department.**

### CAUTION

To avoid eye injury due to uncontrolled release of the firing pin and captured spring, place firing pin side of bolt assembly down against hard surface and then depress firing pin plunger to release the firing pin and captured spring.

## 5.1. Disassembly of the carbine (continued)

### 5.1.3. Bolt and bolt carrier assembly (continued)

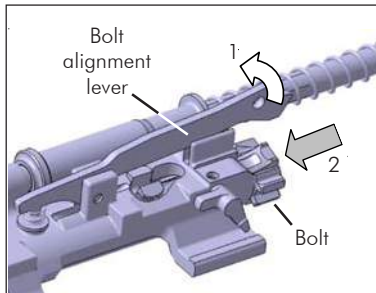

- (1) Raise the tip of the bolt alignment lever and (2) push the bolt to the bottom of its housing.

- (1) Keeping the bolt alignment lever raised and the bolt pushed, pivot the locking cam (1/4 of turn) and remove it. (2) Remove then the bolt out of the slide body.

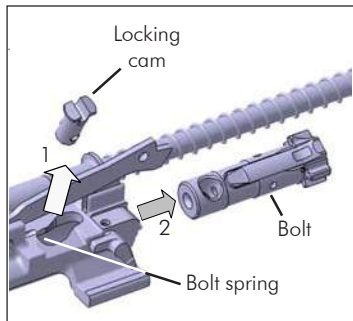

**Do not remove the bolt spring.**

### 5.1.4. Gas plug and piston

#### **WARNING**

After firing, the gas plug can be hot.

- Turn the gas plug clockwise until it stops (in 'weak ammunition' position).
- (1) Using the pointed tip of the tool OREA 892, push the gas plug plunger into its housing to unlock the gas plug. (2) Turn then the gas plug clockwise and (3) remove it out of the barrel receiver.

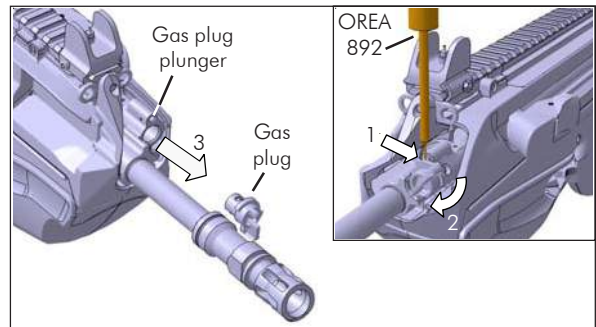

**The accumulated residues on the gas plug could prevent its removal. In this case, use the OREA 892 as lever to turn the latter.**

- If necessary, remove the residues from the head of the gas control screw and from the inner diameter of the gas plug housing using the scraper of the OREA 892.

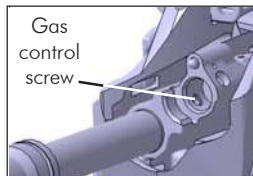

### CAUTION

Check that the gas plug housing is clean. The remaining impurities could damage the piston rings when the piston will be removed.

- Introduce the pointed tip of the OREA 892 into the slide rod housing of the barrel receiver.

### CAUTION

Except OREA 892, do not introduce other things into the slide rod housing.

- Push OREA 892 into the bottom of the slide rod housing of the barrel receiver.

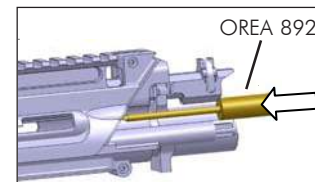

- Introduce the slide rod after the OREA 892 into the slide rod housing of the barrel receiver.

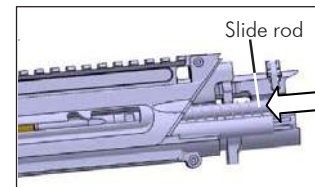

- Push the slide rod until the piston is ejected out of its housing.

**Do not remove the piston rings out of the piston.**

- Remove the slide rod and the tool OREA 892.

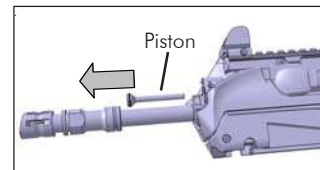

### 5.1.5. Hammer group assembly

- Remove the butt plate proceeding as follows :
  - (1) Pull the lower flexible part of the butt plate rearwards out of the frame;
  - (2) Slide the butt plate upwards and remove it out of the frame.

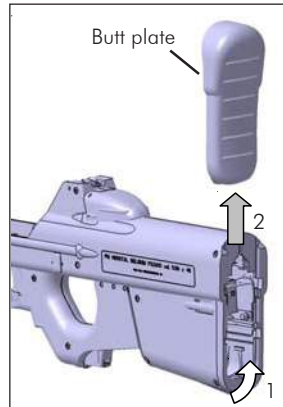

- Remove the hammer group assembly by pulling it out of the frame.

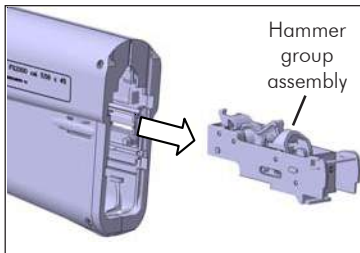

## 5.2. Complementary disassembly

### CAUTION

This level of disassembly is sufficient to perform thorough cleaning : further disassembly should only be carried out by an armorer.

### 5.2.1. Extractor

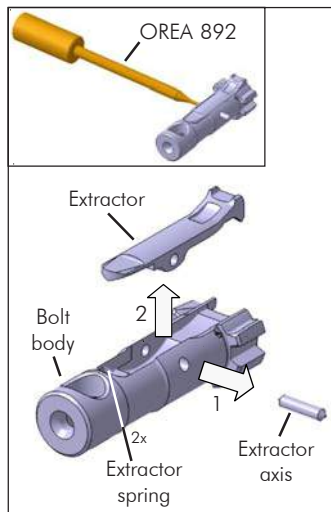

- (1) Using OREA 892, remove the extractor axis from the bolt body.
- (2) Remove the extractor from the bolt body.

### CAUTION

Take care not to lose the 2 extractor springs

### 5.2.2. Handguard

- Push (1) on the rear lugs of the handguard and (2) remove the handguard out of the frame by pulling it downwards.

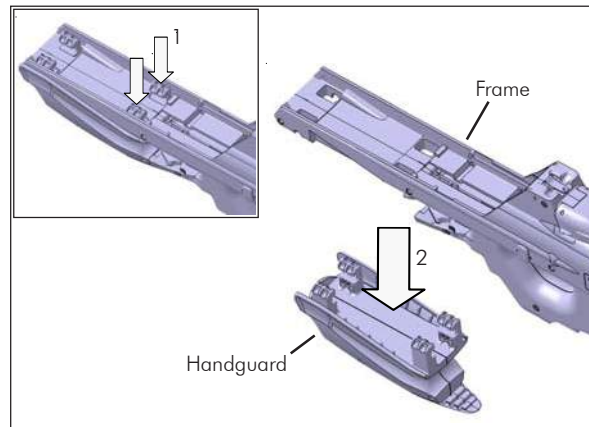

## 5.2. Complementary disassembly (continued)

### 5.2.3. Magazines

#### (a) 10-round magazine

- Press the 2 lugs of the bottom plate lock and then remove it from the magazine body.

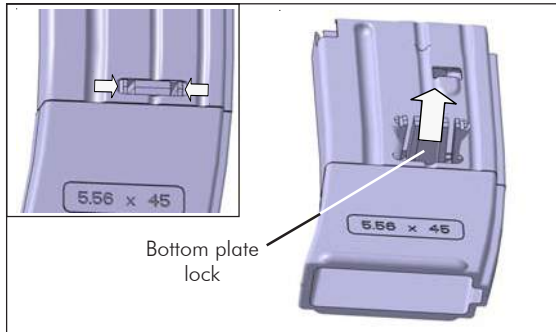

- Remove the bottom plate.

#### CAUTION

Take care to hold the magazine follower spring at the same time so that it does not expand suddenly.

- Remove the magazine follower spring assembled with the magazine follower from the bottom of the magazine body.

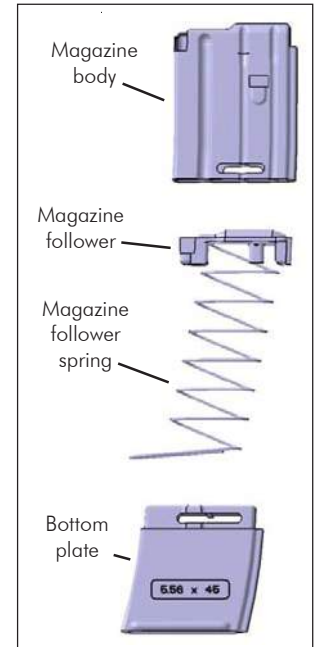

*(b) 30-round magazine*

- Using the rim of a spent round or the tip of a flat head screwdriver, push in the spring on the bottom plate access slot and slide the floor plate off the magazine body to the rear.

**CAUTION**

Take care to hold the magazine follower spring at the same time so that it does not expand suddenly.

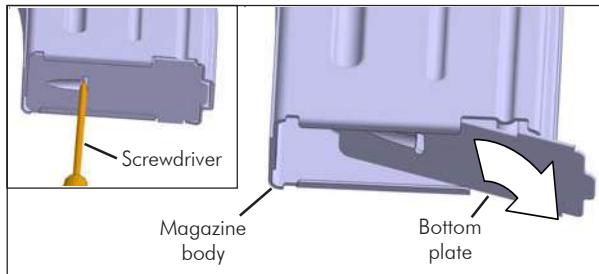

*Depending on the type of magazine used, the removal of the bottom plate could be slightly different.*

- Remove the magazine follower spring assembled with the magazine follower from the bottom of the magazine body.

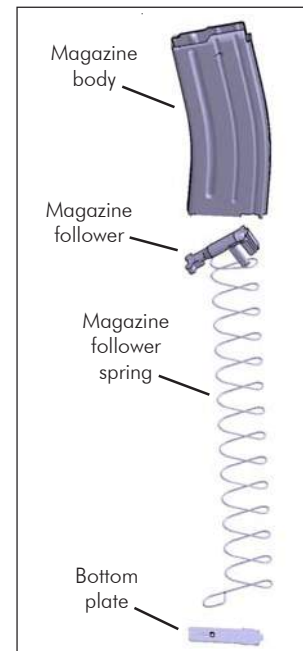

## 5.3. Complementary reassembly

### 5.3.1. Extractor

- Install the extractor on the bolt body taking care to orientate its catch in front of the ejector.

**Check that the 2 extractor springs are installed in their notches of the bolt.**

- (1) Press the extractor to slightly compress the 2 extractor springs and align the hole of the extractor and those of the bolt body.
- (2) Introduce the extractor axis into the corresponding hole of the bolt body.

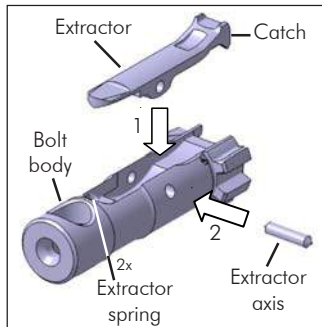

**The extractor axis should not protrude after it has been reinstalled.**

- Once reinstalled, check the correct operation of the extractor by pressing and then releasing it.

### 5.3.2. Handguard

- Position the handguard below the frame so that it is aligned with the tip of the frame. Install the handguard against the frame and firmly push it upwards.

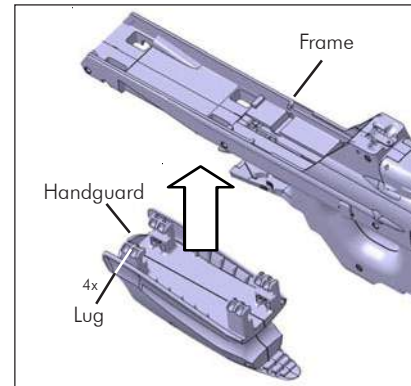

**The lugs of the handguard should be parallel to the top edges of the frame.**



### 5.3.3. Magazines

#### (a) 10 rounds magazine

- Orient the magazine follower and spring as when disassembled and introduce it into the magazine body from the bottom.
- Completely introduce the magazine follower spring into the magazine body and maintain control of it.

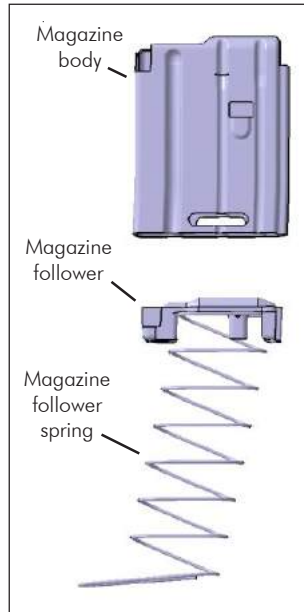

- Position the bottom plate against the bottom of the magazine body and then insert the bottom plate lock into its housing.

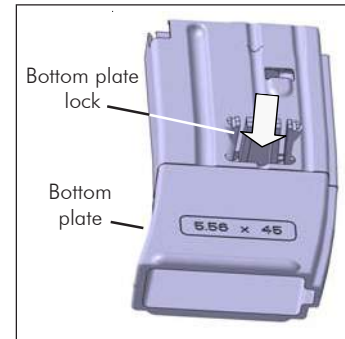

- Ensure that the bottom plate lock is correctly locked and that the bottom plate is seated against the magazine body.

### 5.3.3. Magazines (continued)

#### (b) 30 rounds magazine

- Orient the magazine platform and spring as when disassembled and introduce it into the magazine body from the bottom.
- Completely introduce the magazine platform spring into the magazine body and maintain control of it.

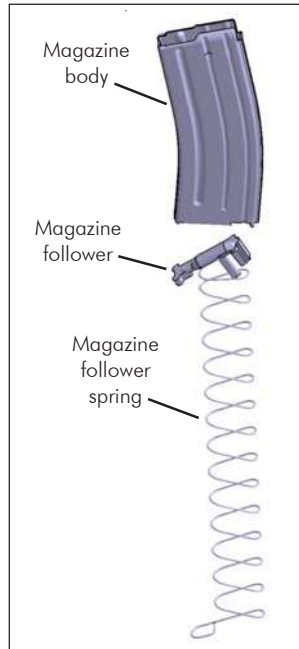

- Slide the bottom plate from rear to front over the magazine platform spring and under the guides until fully seated.

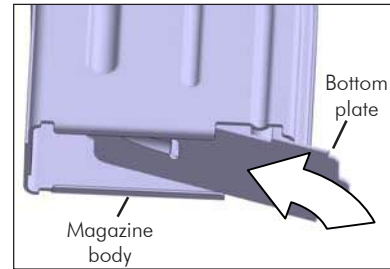

*Depending on the type of magazine used, the reinstallation of the bottom plate could be slightly different.*

- Tap the back of the magazine in the heel of your hand and ensure that the spring is seated in the access slot.

## 5.4. Reassembly of the carbine

### 5.4.1. Hammer group assembly

- If not already done, cock the hammer into the primary sear.

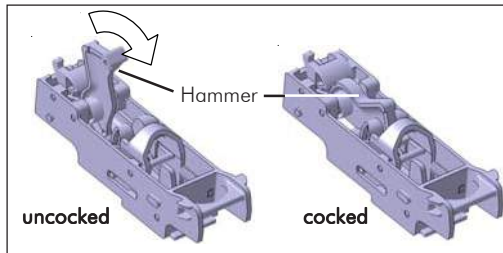

- Install the hammer group assembly into the frame taking care to introduce it along the corresponding notches of the frame.

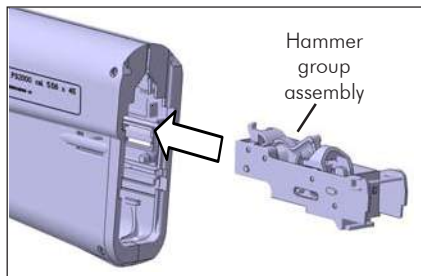

**Check that the hammer group assembly does not protrude out of the frame once reinstalled.**

- Install the butt plate proceeding as follows :
  - (1) Pull the lower flexible part of the butt plate rearwards;
  - (2) Introduce the 2 guides of the butt plate into the corresponding notches of the frame;
  - (3) Slide the butt plate to the end of the notches of the frame.

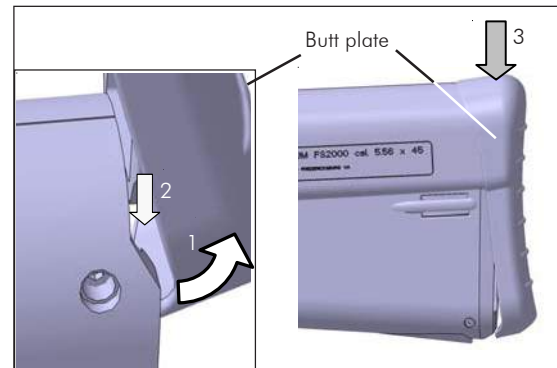

## 5.4. Reassembly of the carbine (continued)

### 5.4.2. Gas plug and piston

- Check that the notches of the 3 piston rings are not aligned to avoid a gas leak by this way.

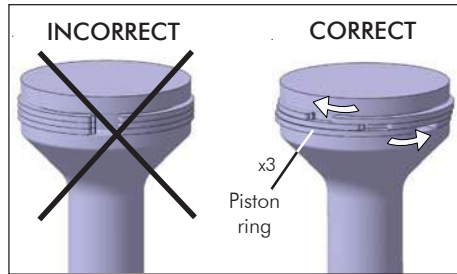

**Reminder : do not remove the piston rings during the field stripping.**

- Install the piston into its housing.

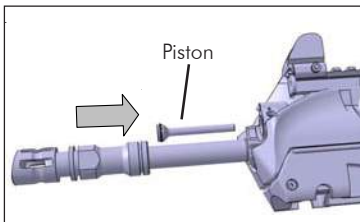

- Install the gas plug in such a way that it does not cover the gas plug plunger.

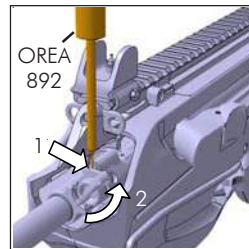
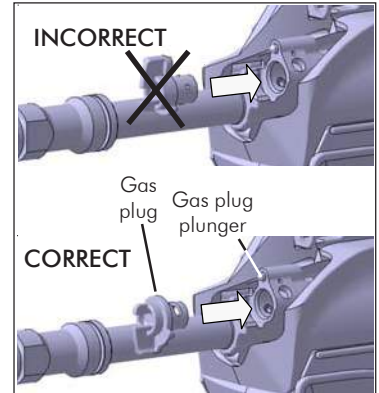

- (1) Using the pointed tip of the tool OREA 892, push the gas plug plunger into its housing and (2) turn the gas plug counterclockwise until the gas plug plunger is locked onto a notch of the gas plug.

- Turn the gas plug counterclockwise until it stops. The gas plug is then positioned at the 'normal' position.

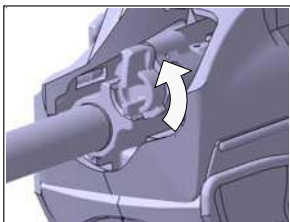

### 5.4.3. Bolt and bolt carrier assembly

**Before reinstalling the bolt, check the mobility of the ejector by pushing and then releasing it. If there is a problem, consult your dealer / departmental armorer.**

- Check if the bolt spring is present inside the slide body.  
*If the bolt spring should be reinstalled, introduce it into its housing of the slide body, push it using the bolt to the housing bottom until it is locked.*
- Introduce the bolt into its housing taking care that the extractor is orientated upwards.
- (1) Raise the tip of the bolt alignment lever and hold it in this position.
- (2) Push the bolt into its housing to align the hole of the bolt with the hole of the slide body.

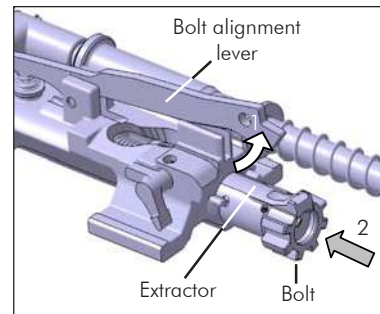

## 5.4. Reassembly of the carbine (continued)

### 5.4.3. Bolt and bolt carrier assembly (continued)

- Holding the bolt, introduce the locking cam orientating its flange upwards.

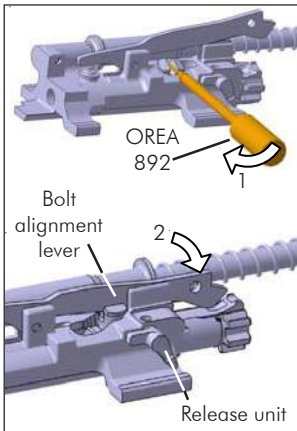
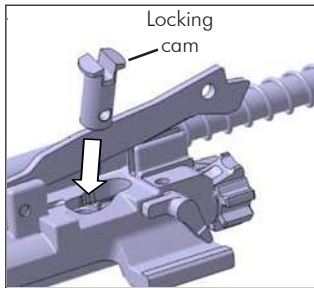

- (1) Still holding the bolt, align the groove of the locking cam parallel to the bolt alignment lever using the tool OREA 892.
- (2) Release the bolt and the bolt alignment lever and check that the alignment lever engages in the groove of the locking cam.

- Check if the extractor works correctly by turning the release unit clockwise (1/4 of turn without excessive strength) : the extractor should raise.

***If the extractor does not raise when the release unit pivots clockwise, check the position of the extractor springs. If the problem is still not solved, consult your dealer / departmental armorer.***

- Introduce the firing pin equipped with the firing pin spring into its housing of the slide body until it is locked by the firing pin retaining plunger.

***The captured firing pin spring must be attached to the firing pin.***

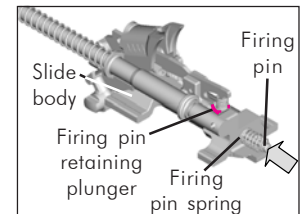

- Position the bolt and bolt carrier assembly vertically by supporting it on the tip of the slide rod. (1) Slide the rear housing return spring downwards to allow the reinstallation of the switch.
- (2 and 3) Position the switch on the slide body by progressively releasing the rear housing return spring which is going to its place due to the return spring.

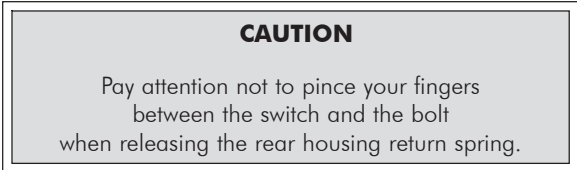
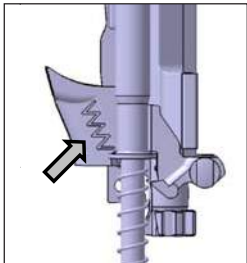
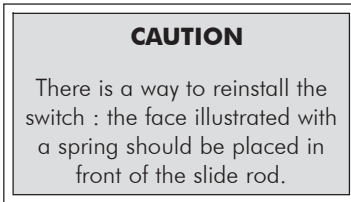
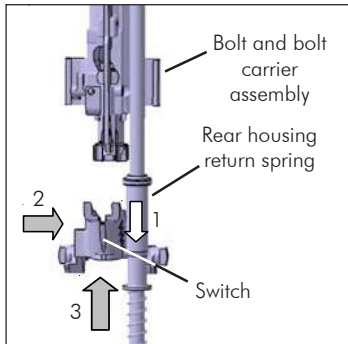

- Introduce the bolt and bolt carrier assembly into the frame taking care to install the switch into the corresponding grooves of the frame.

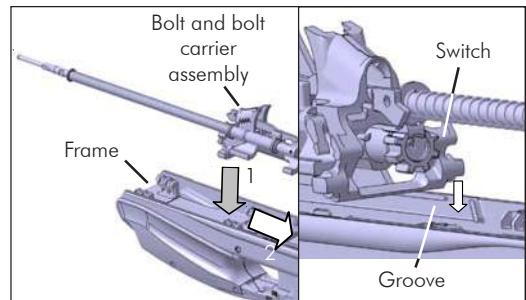

## 5.4. Reassembly of the carbine (continued)

### 5.4.4. Barrel receiver

*Before reinstalling the barrel receiver, ensure that the switch plungers work correctly by pushing and then releasing them.*

- Introduce the barrel receiver on the frame by sliding it along the frame taking care to introduce the sliding rod into its housing.
- Firmly push the barrel receiver until it stops.

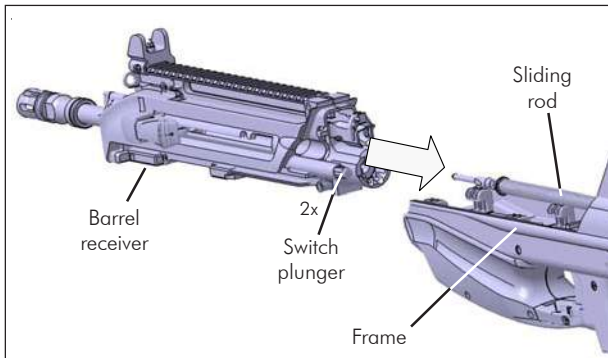

- Press the stripping pin to lock the barrel receiver on the frame.

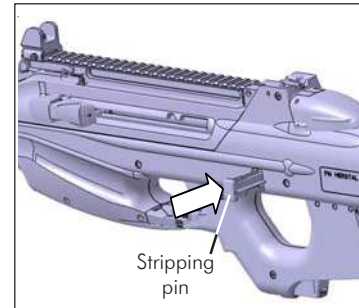

**If the stripping pin could not be pressed, remove the barrel receiver and ensure that the switch is correctly positioned.**



- Examine the outer shape of the carbine and ensure it is correctly reassembled.
- Pull the charging handle completely rearwards and then release it.
- Set the fire selector to the position '1' (**SEMI-AUTOMATIC**).
- Pull the trigger.
- Set the fire selector to the position 'S' (**SAFETY**).

## 6. CLEANING AND LUBRICATION

Before any intervention on the FS2000 carbine, ensure to be familiar with the safety information given in Chapter 1 of this Owner's Manual.

The frequency at which the FS2000 carbine should be cleaned and lubricated depends on the ammunition used, the weather, the shooting conditions and other external factors.

When using normal ammunitions under normal conditions, it is a good rule to clean and lubricate the FS2000 carbine after every use or, in case of intensive shooting, after each 2000 rounds. Correct maintenance will enhance the longevity of the carbine and will ensure a correct operation.

*Excessively dirty ammunition may require more frequent cleaning and too much dirt can affect the functioning of even the finest firearm.*

*It is important to keep your carbine clean and correctly lubricated !*

*Do not use too much lubricant as this could cause the build-up of dirt, grit or powder residue which could affect the functioning of the carbine.*

**Before cleaning the FS2000 carbine, ALWAYS ensure that it is unloaded (see § 4.5).**

**Keep the ammunition away from the cleaning site and never test the mechanical function of your carbine with live ammunition.**

Before each shooting sequence, ALWAYS check the barrel for obstructions and ensure that it is dry and clean.

*Completely clean the carbine, ensure that there is no round in the chamber and then, after having cleaned its bore, glance down the barrel in order to ensure that it is free of any obstruction.*

*Take into account that the smallest obstruction can dangerously increase pressure.*

## 6.1. Lubricant and solvents specifications

FN HERSTAL recommends using lubricant Nycolube 127 CLP or equivalent (reference US MIL-PRF-63460 or NATO S-758).

*For the US Market, CLP is available under the following names and trademarks :*

- CLP-NC by BREAK-FREE INC
- SENT-CLP by SENTINEL CANADA
- ROYCO-634 by ROYAL LUBRICANTS Co, INC

*Be aware that some solvents can be harmful to the surface finish of the carbine, so consult your dealer / departmental armorer.*

Never use trichloroethylene nor ammonia :  
they could cause damage to the carbine !

## 6.2. Cleaning and lubrication tools

### 6.2.1. Tool and combination scraper OREA 892

The tool and combination scraper OREA 892 contains the following tools :

- A scraper OREA 892A,
- A plug OREA 892B.

The scraper OREA 892A features 2 different tips with proper utility :

- A scraper  
*The scraper is used to scrape the residues stuck on the gas plug, the piston and the gas plug housing.*
- A pointed tip  
*The pointed tip is used as drift punch or for other handlings during field stripping (see chapter 5).*

To use it easily, the scraper OREA 892A is fitted into the plug OREA 892B.



### 6.3. Cleaning and lubrication before firing

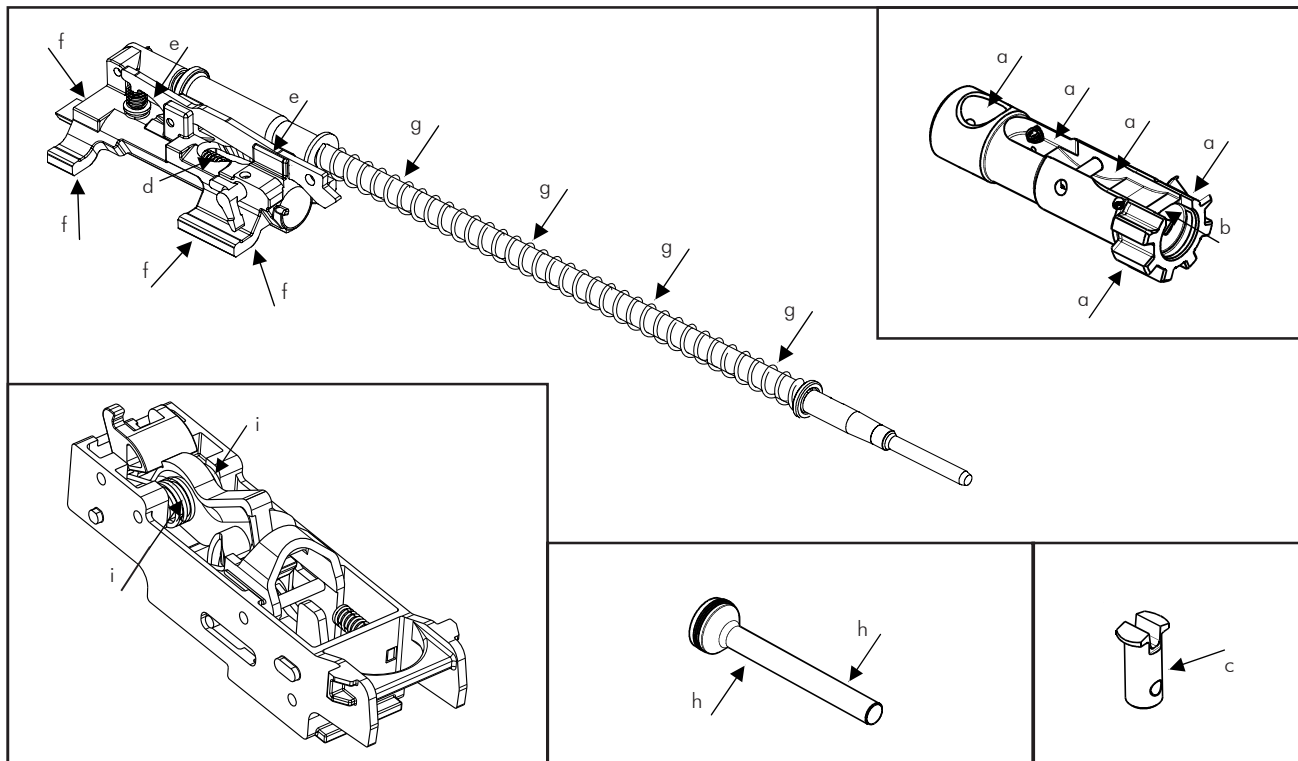

***The following procedure assumes that the FS2000 carbine has correctly been cleaned and lubricated the last time it has been used (see § 6.4).***

- Carry out the field stripping procedure (see § 5.1) and, if necessary, some parts of the complementary disassembly procedure (see § 5.2).
- Introduce a cleaning handle (equipped with a swab) into the barrel through the chamber. Fit a clean rag (a piece of flannel) into the swab and then remove the cleaning handle to remove the maintenance lubricant. Repeat this handling until the piece of flannel goes clean out of the barrel.
- Using a soft cloth, clean the bolt and bolt carrier assembly proceeding as follows :
  - Wipe the external surfaces of the bolt and bolt carrier assembly clean.
  - Wipe the return spring clean.
  - Compress the return spring and wipe the liberated part of the slide rod clean.
  - Push the rear housing return spring to compress the return spring and wipe the visible part of the slide rod clean.
- Lubricate the bolt and bolt carrier assembly proceeding as follows :
  - Oil the bolt body (arrows a).
  - Oil the ejector and ensure it is completely lubricated by pushing and then releasing it several times (arrow b).
  - Slightly oil (1 drop of oil) the locking cam (arrow c) and the unlocking ramp (arrow d).
  - Slightly oil (1 drop of oil) the bolt alignment lever (arrows e).
  - Oil the slides of the slide body (arrows f).
  - Oil the slide rod on its overall length (arrows g).
  - Push the rear housing return spring to compress the return spring and oil the visible part of the slide rod (arrows g).
- Oil the piston rod (arrows h).
- Slightly oil (a drop of oil) the 2 hammer springs (arrows i).
- Reassemble the carbine (see § 5.3 and § 5.4).

## 6.4. Cleaning and lubrication after firing

- Carry out the field stripping procedure (see § 5.1) and, if necessary, some parts of the complementary disassembly procedure (see § 5.2).

### 6.4.1. Barrel receiver

- Clean the chamber proceeding as follows :
  - Introduce a chamber cleaning brush into the chamber.
  - Clean the chamber by turning the chamber cleaning brush.

#### CAUTION

Do not force during the introduction of the chamber cleaning brush into the chamber.

- Remove the chamber cleaning brush from the chamber.

- Using the chamber cleaning brush, clean the piston housing of the gas block proceeding the same way as for the chamber (see upper).

#### CAUTION

Do not force during the introduction of the chamber cleaning brush into the piston housing of the gas block.

- Using the scraper OREA 892A, scrape the front face and the rod of the piston to remove the residues.

#### CAUTION

Do not scrape the piston rings.

- Using the scraper OREA 892A, scrape the gas plug to remove the residues until having a smooth surface.

- Introduce a cleaning brush through the chamber and clean the inside of the barrel on its overall length with backward and forward motion until it is visually clean.
- Introduce a cleaning handle (equipped with a swab) into the barrel through the chamber. Fit a clean rag (a piece of flannel) into the swab and then remove the cleaning handle to remove the maintenance lubricant. Repeat this handling until the piece of flannel goes clean out of the barrel.
- Once the inside of the barrel is clean, to protect it until the next use, carry out this handling one more time using a piece of flannel slightly oiled.
- Oil the piston rod.
- Oil the 2 switch plungers.

#### **6.4.2. Bolt and bolt carrier assembly**

- Using a cleaning brush, remove the copper particles stuck on the bolt.
- Using a cleaning brush, remove the particles stuck on the extractor.
- Using a soft cloth, wipe the locking cam and the firing pin clean.
- Using a soft cloth, clean the bolt and bolt carrier assembly proceeding as follows :
  - Wipe the external surfaces of the bolt and bolt carrier assembly clean.
  - Wipe the return spring clean.
  - Compress the return spring and wipe the liberated part of the slide rod clean.
  - Push the rear housing return spring against the compressed return spring and wipe the liberated part of the slide rod clean.

## **6.4. Cleaning and lubrication after firing (continued)**

### **6.4.2. Bolt and bolt carrier assembly (continued)**

- Lubricate the bolt and bolt carrier assembly proceeding as follows :
  - Oil the bolt body.
  - Oil the ejector and ensure it is completely lubricated by pushing and then releasing it several times.
  - Slightly oil (1 drop of oil) the locking cam and the unlocking ramp.
  - Slightly oil (1 drop of oil) the bolt alignment lever.
  - Oil the slides of the slide body.
  - Oil the slide rod on its overall length.
  - Push the rear housing return spring to compress the return spring and oil the liberated part of the slide rod.

### **6.4.3. Hammer group assembly**

- Check the general cleanness of the hammer group assembly. If necessary, use a soft cloth to clean it.
- Slightly oil (1 drop of oil) the 2 hammer springs.



#### **6.4.4. Frame and handguard**

- Check the general cleanness of the frame and the handguard. If necessary, use a soft cloth to clean them.
- Check the general cleanness of the 2 metallic rails located inside the frame. If needed, using a cleaning brush, clean the 2 metallic rails.
- Oil the 2 metallic rails located inside the frame.

*To allow a good oil flow on the overall length of the metallic rails, position the carbine vertically and wait some minutes for the completed oil flow.*

#### **6.4.5. Magazine**

- Check the general cleanness of the magazine. If necessary, use a soft cloth to clean it.
- The inside of the magazine can slightly be oiled and then directly wiped using a soft cloth.

Reassemble the carbine (see § 5.3 and § 5.4).

## 7. TAKING CARE OF THE CARBINE

- ✓ Always keep the carbine in immaculate condition and good working order.
- ✓ Always clean and lubricate the carbine after use.
- ✓ Regularly inspect the carbine, its parts and accessories.  
*If something seems abnormal, do not hesitate to report it to your dealer / departmental armorer.*
- ✓ Never modify or repair parts of your carbine (or any other one) by yourself.

**Your carbine is a mechanical device subject to wear and which will not last forever : it requires periodic inspection, adjustment and service.**

**The carbine should be checked every 10,000 rounds and/or once a year because damage, wear, corrosion, ... are not always visible from the outside. For that purpose, send the carbine to your dealer.**

**Law enforcement personnel has a departmental armorer which will inspect the carbine on a yearly basis.**

**FN HERSTAL can not assume any responsibility for injuries caused by unauthorized servicing, alterations or modifications to its firearms.**

## 8. TROUBLESHOOTING

Before any intervention on the FS2000 carbine, ensure to be familiar with the safety information given in Chapter 1 of this Owner's Manual.

### 8.1. Immediate actions

- If the carbine fails to fire :
  - Set the fire selector to position **'S' (SAFE)**.
  - Remove and check the magazine.
  - If the magazine is empty :
    - Insert a loaded magazine.
    - Cock the weapon.
    - Set the fire selector to position **'1' (FIRE)** and resume firing.
  - If there are still rounds in the magazine :
    - Pull the charging handle fully to the rear and release it.
    - Check that the rounds are correctly positioned in the magazine.
    - Insert the magazine.
    - Cock the weapon.
    - Set the fire selector to position **'1' (FIRE)** and resume firing.

- If carbine does still not fire :
  - Set the fire selector to position **'S' (SAFE)**.
  - Remove the magazine.
  - Pull the charging handle fully to the rear and hold it.
  - Pressing the charging handle upwards let it move forwards without releasing it, the handle will be held to the rear after a short movement.
  - Open the cover, check that the chamber and receiver are clear, close the cover.

#### **WARNING**

Never try to remove a cartridge or a case by hand.  
Use a tool such a screwdriver.  
Do not strike the primer of a cartridge with the tool.

- Insert a loaded magazine.
- Release the charging handle by pushing it downwards.
- Set the fire selector to position **'1' (FIRE)** and resume firing.

## 8.1. Immediate actions (continued)

- If there are no rounds or cases trapped in the receiver, and if the bolt does not fully close and lock :
  - Pull the charging handle back until it contacts the bolt carrier rod and rotate it outwards.
  - Maintaining it in an extended position, push the charging handle forwards.
- In case of repeated stoppages :
  - If the carbine is :
    - dirty due to prolonged firing or lack of thorough cleaning.
    - has been exposed to sand, dust or mud.
    - is not well lubricated.
  - Rotate the gas plug to the left.

### WARNING

After firing, the gas plug will be very hot.

- If stoppages continue, clean and lubricate the carbine.
- After the carbine has been cleaned and lubricated the gas plug must be rotated to the right.

*If the carbine continues to have stoppages it must be inspected and repaired by an authorized dealer or armorer.*

## 9. ACCESSORIES

### ➤ Sling



### ➤ Tactic sling



### ➤ Handguard, tri-rail

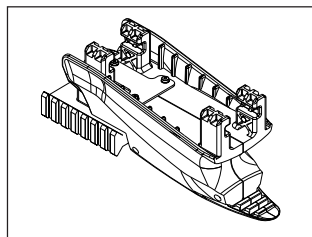

- Pistol grip for Picatinny rail (only for the handguard, tri-rail)



**NOTES**

**NOTES**



# **FN HERSTAL**

**FNH USA, LLC  
PO Box 697  
McLean, VA 22101**