

GERMAN SPORT GUNS GMBH GSG-STG44



GERMAN SPORT GUNS

Handling and Safety Instructions

USA

ATI Warranty Service Policy & Procedure

ATI 2 year limited warranty on imported goods

American Tactical Imports provides warranty services, parts and repairs for our imported products. If you believe your ATI imported product or ATI brand products needs service or replacement, please contact 1-800-290-0065 or email techservice@americantactical.us. One of our representatives will assist you and provide all instructions.

If you are contacting ATI for service of a firearm please have your serial number available. All returns for service or repair require a **Return Authorization (RA)** number to be issued by an ATI representative. **No returns for service will be accepted without an ATI issued RA number written clearly on the outside of the package.** Any items received without an ATI issued RA will be returned to the sender without action.

Service time frame may vary due to service cue and availability of parts from foreign manufacturers. It is the responsibility of the consumer to ship any firearms or products to ATI for service. All firearms must be registered by mail in registration form or online registration before an ATI representative can issue a return authorization number.

If an item received is outside of warranty coverage, an ATI representative will contact you before further action is taken.

The warranties covered by ATI are implemented and monitored by the foreign manufacturers of all ATI imported products. ATI reserves the right to deny or decline any warranty services or products what do not meet the warranties implemented by our manufacturers.

If you are returning a rifle or shotgun for services, you may ship to ATI via US Postal Service or any parcel delivery service directly to ATI.

If you are returning a pistol, it is the responsibility of the owner to contact a local FFL to ship to ATI. All warranty service information must be provided by the FFL who is shipping the pistol.

All firearms returned to ATI for service can only be shipped back to the original senders address. Change of return shipping address once received is not authorized. Pistols can only be shipped to and from FFL locations.

If you have any questions or concerns regarding ATI's warranty policy or services please contact us at 1-800-290-0065 or email at customerservice@americantactical.us.

Contents	Section	Page
History of the StG 44	D-01	05
Product description	D-02	06-07
General Instructions / Safety regulations	D-03	08
Technical Data	D-04	09
Main parts / Assembly groups of GSG StG 44	D-05	10
Safety mechanism	D-06	11
Transporting the Rifle	D-07	12
General	D-08	12
Ammunition	D-09	12
Loading the magazine	D-10	13
Loading the weapon	D-11	14
Firing	D-12	15-16
Interruption of Shooting	D-13	17-18
Decocking the hammer	D-14	19
Adjusting the Sight	D-15	20
Maintenance and disassembly the weapon	D-16	21-22
Cleaning of the chamber and the breech block	D-17	23
Care of the gun	D-18	24
Troubleshooting / Removal	D-19	25
Storage of the gun	D-20	26
Shipping the weapon to the manufacturer	D-21	26
Accessories	D-22	27
Disposal	D-23	27
Spare Part List	D-24	27

D-01: History of the StG44

The StG44, Sturmgewehr 44, or assault rifle model of 1944 was an assault rifle developed in Germany during World War II and was the first of its kind to see major deployment, considered by many historians to be the first modern assault rifle. It is also known under the designations MP43 and MP44 (Maschinepistole 43, Maschinepistole 44, respectively), which denote earlier development versions of the same weapon. This rifle was in service from October 1943 - May 1945. GSG took the decision to restore this Legend of the world wide assault rifle for all gun enthusiast and firearm collectors. The GSG-StG44 in Caliber .22 is an outstanding replica of this gun.

Origin: http://de.wikipedia.org/wiki/Sturmgewehr_44



GSG-StG44

D-02: Product description

Dear valued customer,

this Rifle has been constructed for caliber .22 lr HV ammunition. Because of the high range of caliber .22 ammunition we decided to adjust the StG44 to high quality Standard- as well as HV-ammunition.

When you take out your StG44 of the box the first time, please assemble the buttstock with the enclosed take down pin. (see figure 1 & 2 on page 7

We wish you much pleasure with our product.

info@germansportguns.de

www.gsg-guns.com

www.americantactical.us





Figure 1

Assembling of the buttstock after removing it from the box.



Figure 2

D-03: General Instructions / Safety regulations

Never use the gun under the influence of drugs or alcohol, while ill or suffering other such difficulties.

These conditions can impair your powers of judgement and reflexes.

Always think of the gun as being loaded and with the safety off until you have established the opposite through the unloading procedure.

Always keep the muzzle of the gun in a safe direction when handling. A safe direction is towards an area where there are no people, other life forms or property that is not a recognized target.

Never point the gun at doors, panes of glass, walls, concrete, stone or flat surfaces (water included).

A bullet can penetrate such surfaces or be ricocheted in an unsafe direction.

Never aim at yourself or other life forms.

Never rely on safety mechanism alone. Safety mechanism may not be functioning. The best safety precaution is a correct, well trained and be safe handling of the gun.

Never shoot with a gun which has been penetrated by water, sand, dirt or other foreign bodies.

Never decock the hammer by holding on the hammer and pulling the trigger at the same time.

Never let a loaded gun out of your hands.

Always unload the gun immediately after firing, before putting the gun away, putting into a holster or handing to another authorized person.

Never give the gun to a person that has not thoroughly familiarized himself or herself with the safety instructions and handling of the gun, by reading the corresponding instructions.

Never leave the gun lying unattended and protect the gun from unauthorized access. Unauthorized person could do damage, or threaten or kill others and you will be vicariously liable.

Never store the gun loaded, but rather remove the magazine and ensure that no cartridge is left in the chamber of the barrel.

Always keep the gun and the ammunition separate from another, and ensure that neither is obtained by unauthorized persons or childrens.

Always wear eye and ear protection when shooting.

D-04: Technical Data:

Caliber .22 Long Rifle HV 22

Overall length 946,5 mm / 37,3 inch

Overall height 220,5 mm / 8,7 inch

Overall width 56 mm / 2,2 inch

Barrel length 414 mm / 16,3 inch

Rifling length 406 mm / 15,9 inch

Number of grooves 6

Sight length 435 mm / 17,1 inch

Weight without magazine 4,15 kg / 9.15 lb

Weight of the magazine 0,26 kg / .57 lb

Trigger pull, approx. SA < 3 kg / 6.6 lb

Magazine capacity / rounds 25 / 15 / 10 / 2

Whats in the Box:

1 GSG-StG44

1 Magazine

1 Handbook

1 Cleaning brush

1 Buttstock

1 Loaded chamber indicator

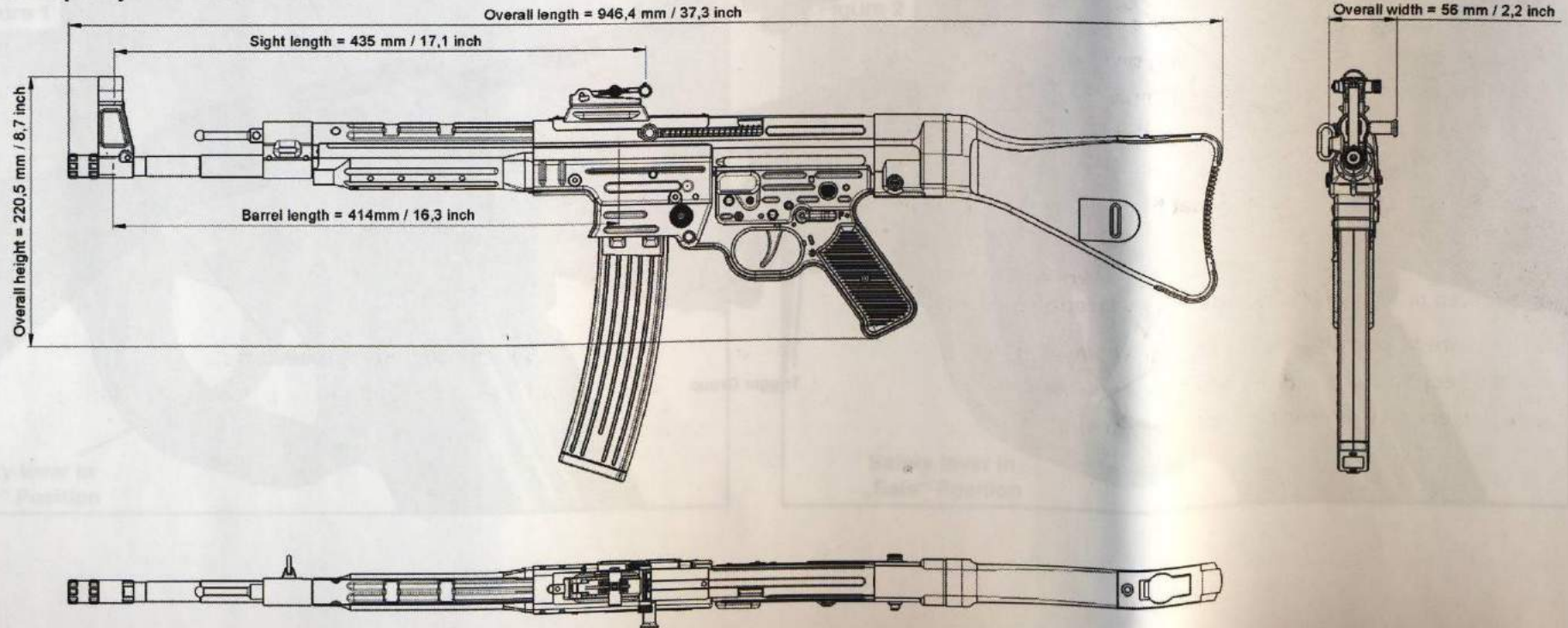

D-05: Main parts / Assembly groups of the GSG-StG44

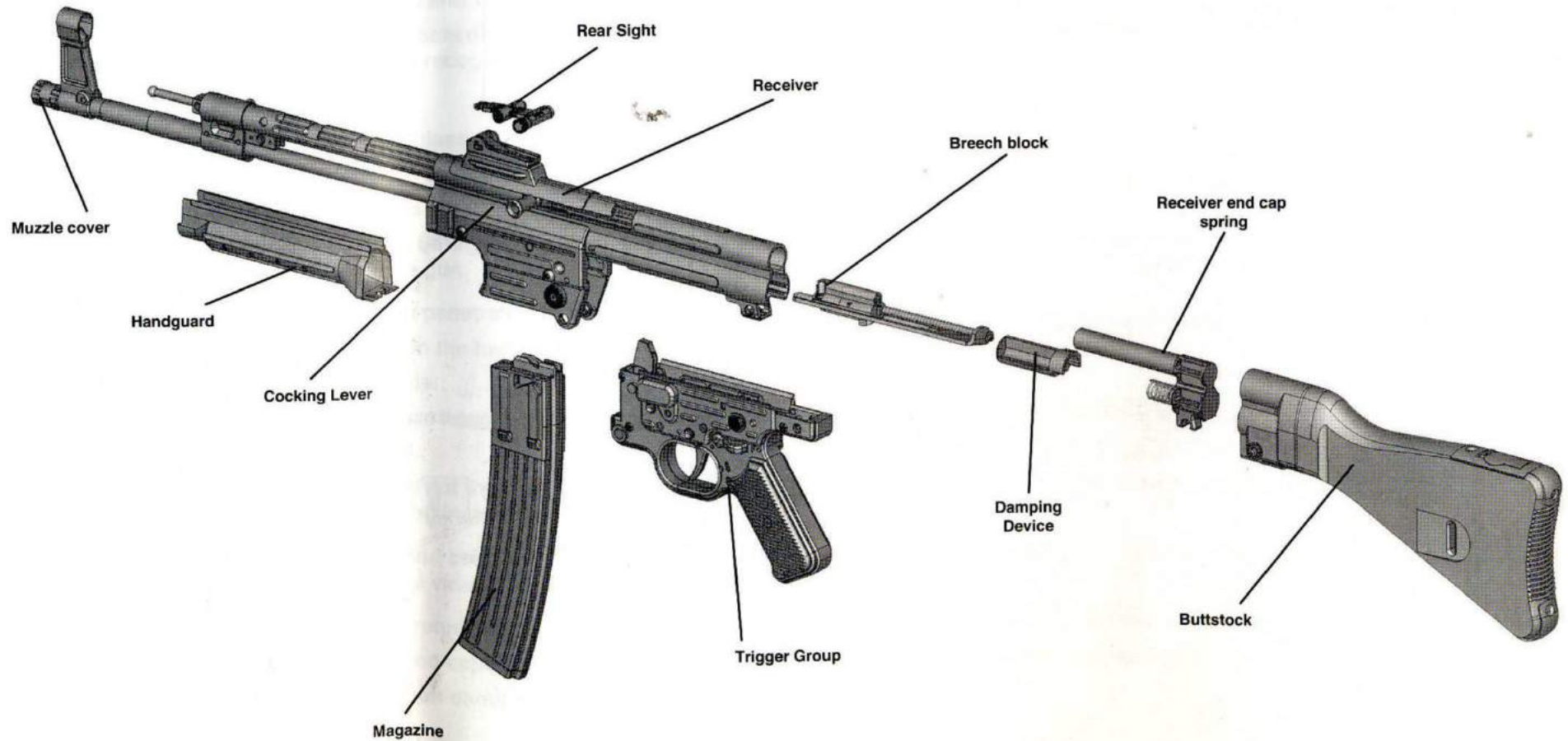

D-06: Safety mechanism

Put the safety lever in the top position „F“ to release the trigger.
Press the safety lever down to the „S“ position to lock the trigger.

„S“ = SAFE / „F“ = FIRE

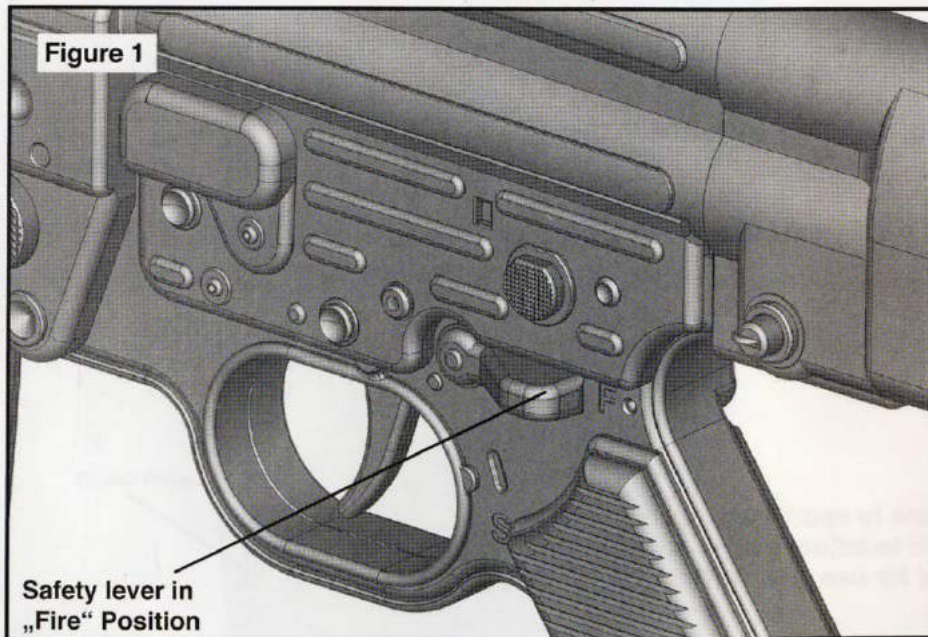

D-07: Transporting the Rifle

- For your own safety and the safety of others, always transport the gun with the „Loading Chamber Indicator“, in place with the gun, unloaded, decocked and locked.
- Never carry a gun with you that has already been cocked and that has a round in the chamber.
- While carrying a gun always make sure that direction of muzzle will be under your control in case of a fall or any other slip.
- Transport the gun separately from the ammunition.
- Ensure that all applicable laws governing the transport of firearms are complied with.

D-08: General

The gun is generally delivered with a thin, protective grease and oil coating.

D-09: Ammunition

- For your gun, use only commercial grade ammunition in its original packaging, that corresponds with the caliber of the gun.
- The correct caliber is imprinted on the gun.
- Never use reloaded, refurbished, hand-loaded or non standard ammunition of a different caliber.
- Never use dirty, wet, corroded, bent, damaged or oiled ammunition.
- Never leave the ammunition lying unattended.

Information:

The .22 ammunition spectrum ranges from very light loads for single loader guns to sport load, utility load and on through to high speed rounds. Unfortunately, however, it is not possible to adjust a semi-automatic gun to all loads. We have therefore decided to make an adjustment to the load that have priority for use with GSG StG44 which are high quality utility and high-speed rounds.

D-10: Loading the Magazine:

Procedure:

1. Put the cartridge on the follower, near the magazine feed lips. (Figure 1 page 13)
2. Pull down the thumb piece of the magazine.
3. Push the bullet to the backside of the magazine. (Figure 2 page 13)
4. Load only the quantity of bullets into the magazine you want to fire. (max. 25 / 15 / 10 / 2)
5. Never try to load ammunition in a magazine than its intended amount.

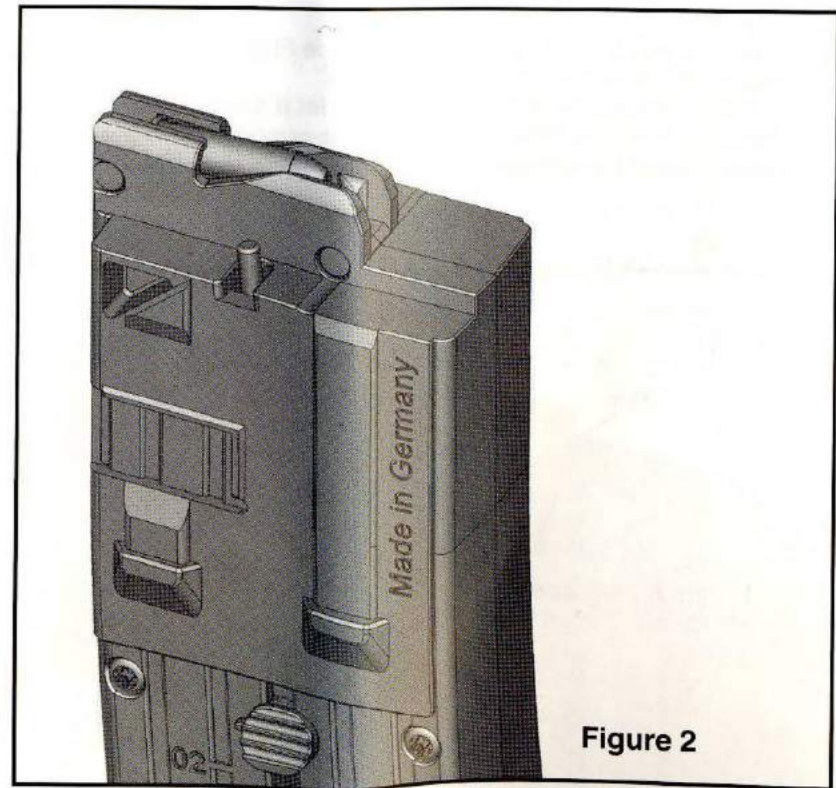
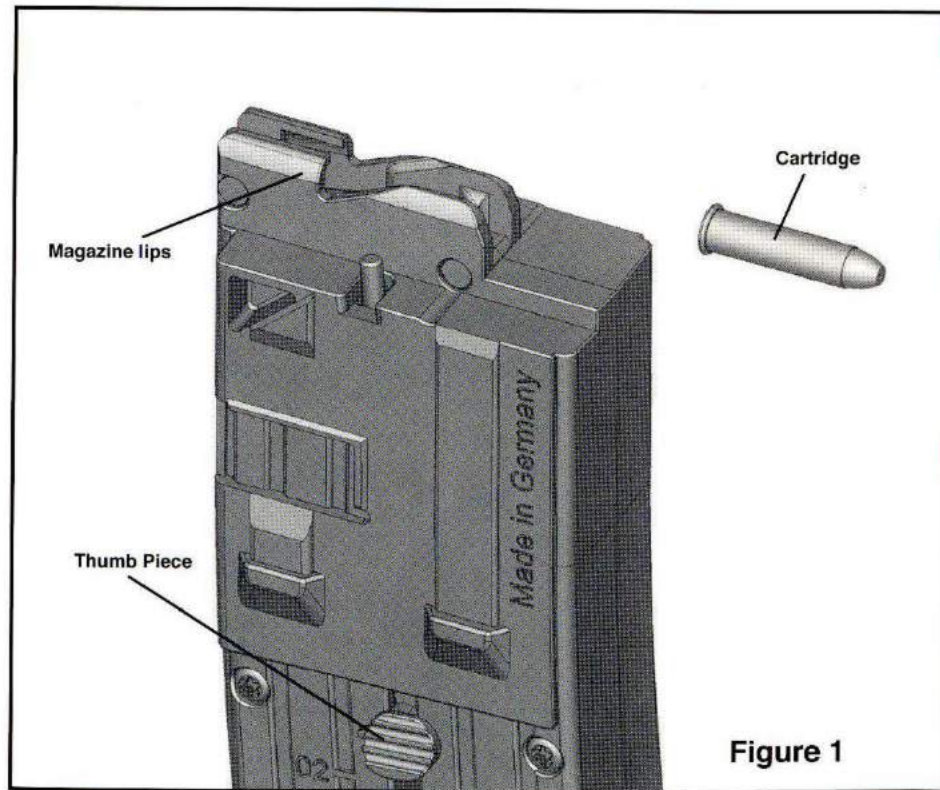

D-11: Loading the Weapon

Notice:

- Never load or reload the gun in a vehicle, a room or confined area (Except a shooting range)
- Before loading always wipe off any excess grease and oil and check to see if there are any foreign objects/material in the barrel.
- Always keep the muzzle of the gun pointed in a safe direction.
- Don't put your finger on the trigger. Keep your finger outside the trigger guard.
- Load the gun by pushing in the magazine only directly before firing.
- Pull the cocking lever to load the first bullet.
- Never rely on the safety mechanism alone. Safety mechanisms are not a substitute for careful and correct handling of the gun.
- Never let a loaded gun out of your hands.

Procedure:

1. Put the safety lever to position „S“ (see Figure 2 page 11)
2. Insert the loaded magazine.
3. Pull the cocking lever backwards and let it slide forwards. The flap opens at the same time. (see Figure 1 page 14)
4. The breech is now closed and the first cartridge is in the chamber. (see Figure 1 page 12) The gun is loaded.
5. Immediately before firing put the safety lever to position „F“ (see Figure 1 page 9)

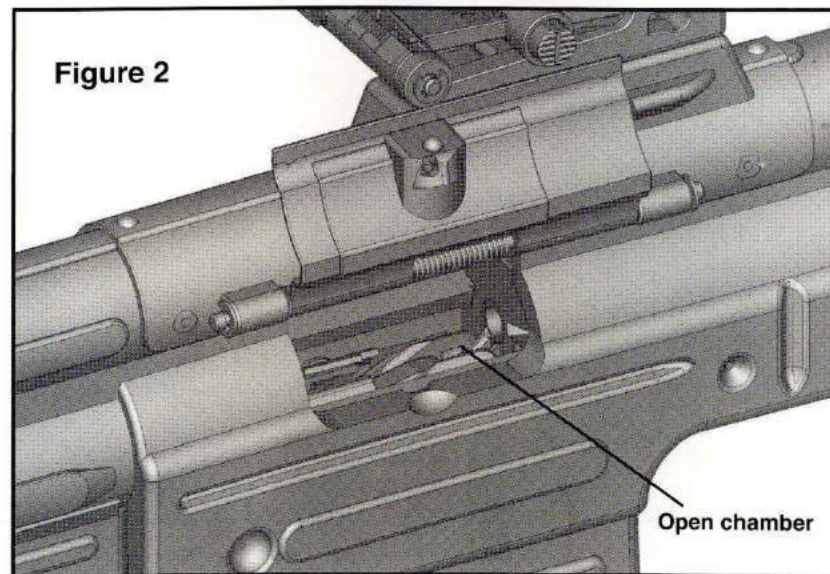
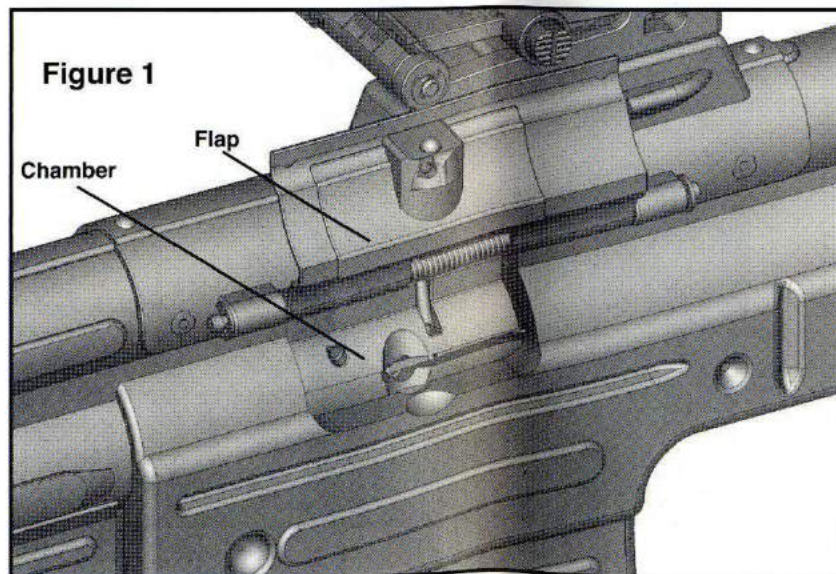

D-12: Firing

- Ensure that the target and surroundings allow shots to be fired without danger.
- Ensure during firing that your fingers, hands or other parts of the body are not in front of, above or beside the barrel or the ejection port.
- Never allow any person to stand next to you where they could be hit by ejected cartridge cases.
- When shooting, always wear ear protection and protective eye glasses. Inform other people close to you about the need to wear ear and eye protection.
- Interrupt shooting immediately and unload the gun if you suspect that a round is not inserted correctly, a case is jammed, a round may have blocked the barrel or a shot sounds or gives the sensation that it may be „weak“ or unusual and should be checked. Pull the cocking lever backwards and hold it in this position. Put the safety lever on the „S“ position with the other hand. (see Figure 1 & 2 on page 11) Now the ejection port will be kept open by the cocking lever and can be checked. (see Figure 1 & 2 on page 16) Never try to dislodge a blockage by firing another round.

**Important: During firing hold the gun on the handguard and not on the magazine!
Holding the gun on the magazine can cause malfunctions!**



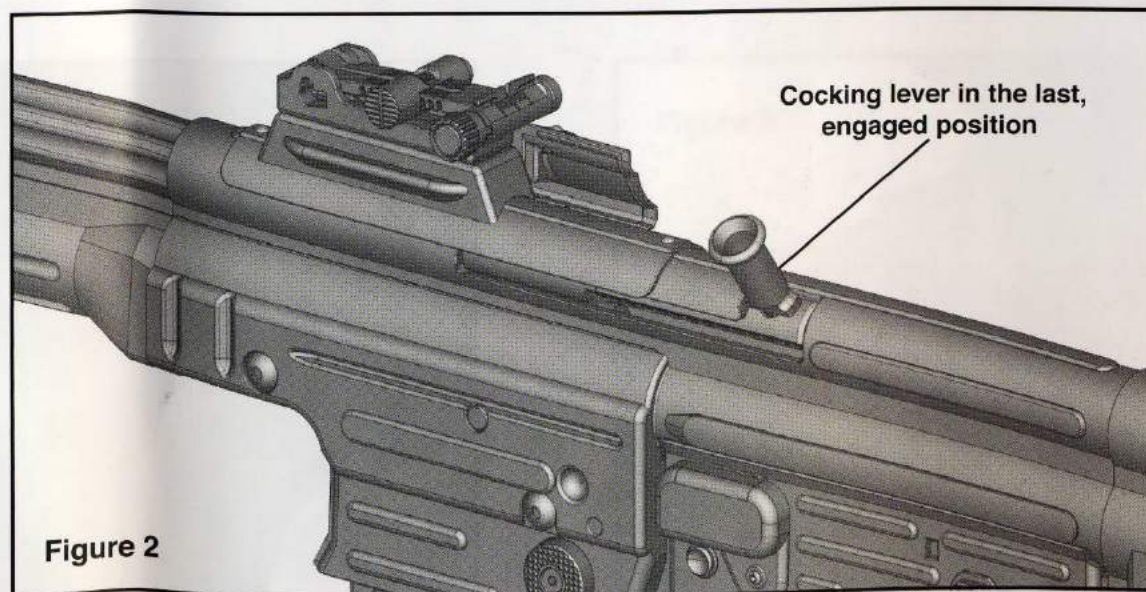
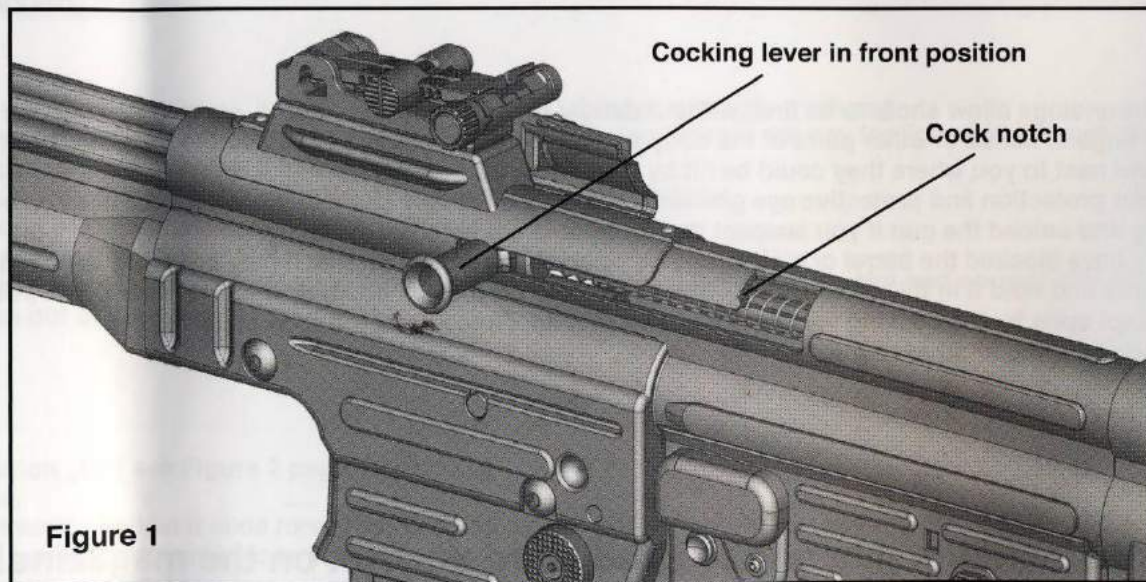

D-13: Interruption of shooting (Magazine not empty)

Notice:

- Never let the gun out of your hand before it is unloaded.
- When the gun is loaded; a round is in the chamber.
- Never place your hand over the ejection port.

Procedure:

1. Move safety lever to the „S/Safety on“ position. (see Figure 2 on page 11)
2. Keep the muzzle of the gun in a safe direction.
3. Remove the magazine and store it safely.
4. Pull the cocking lever backwards and engage it. The cartridge will be ejected.
5. Check to make sure the chamber is empty. (see Figure 1 on page 18)

Important: The gun is now unloaded but the hammer is not decocked!

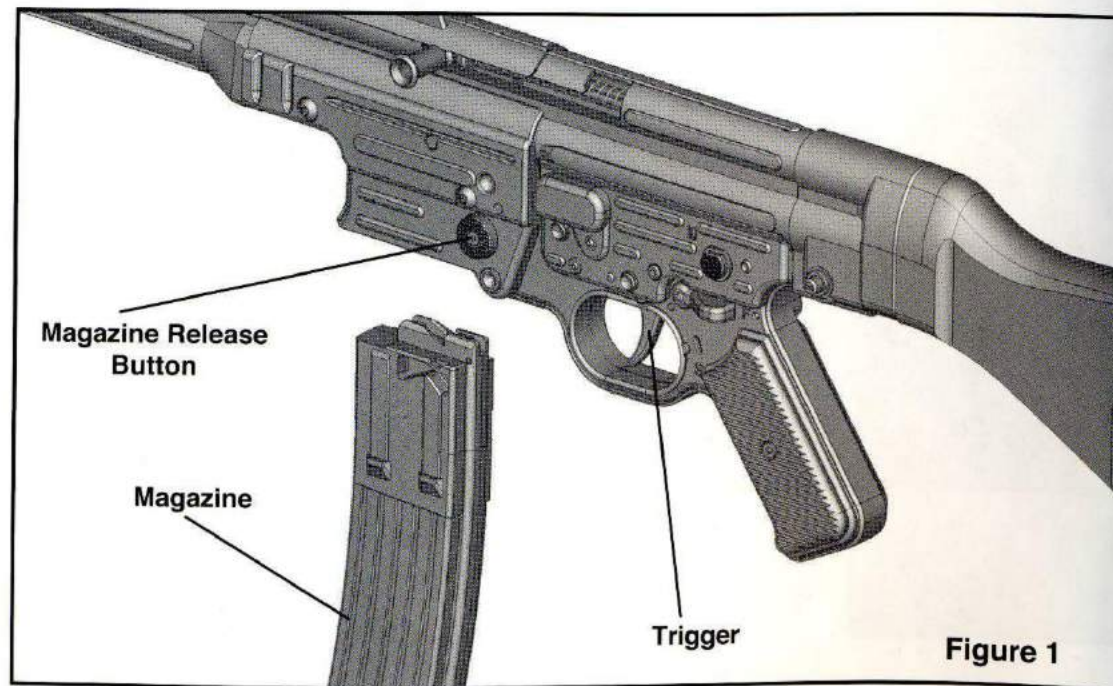
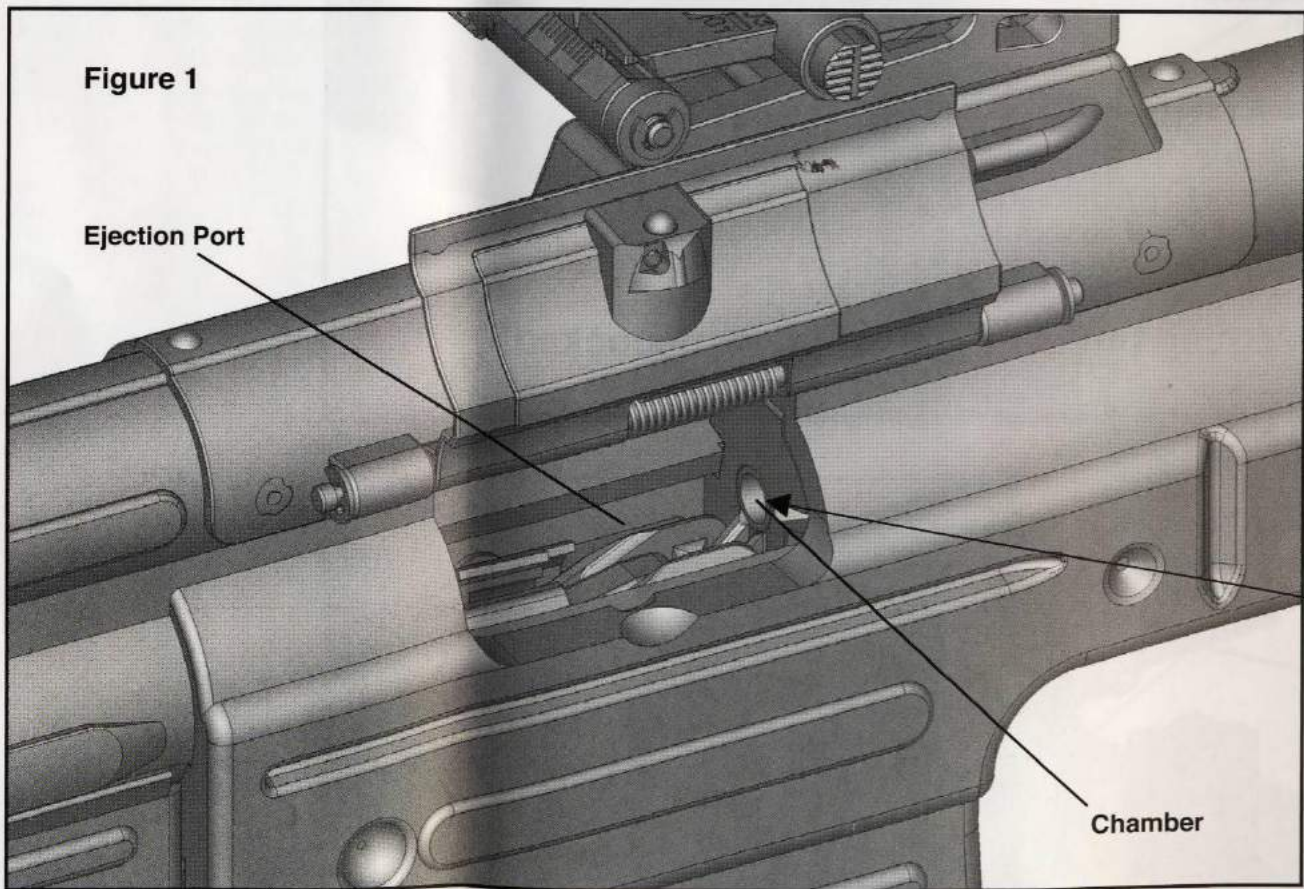

Figure 1

Ejection Port



Chamber

Level Indicator

Figure 2

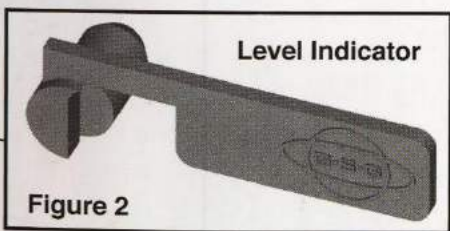

D-14: Decocking the hammer

Notice:

- Pull the trigger only, if the loaded chamber indicator is inserted in the chamber
(see Figure 2 on page 18)

Procedure:

- 1 Ensure that there is no more round in the chamber. Then insert the loaded chamber indicator in the chamber.
2. Pull the cocking lever backwards and let it slide forwards.
3. The safety lever has to be in position „F“
4. Pull the trigger. The hammer trips and is decocked. Put the safety lever again to „S“

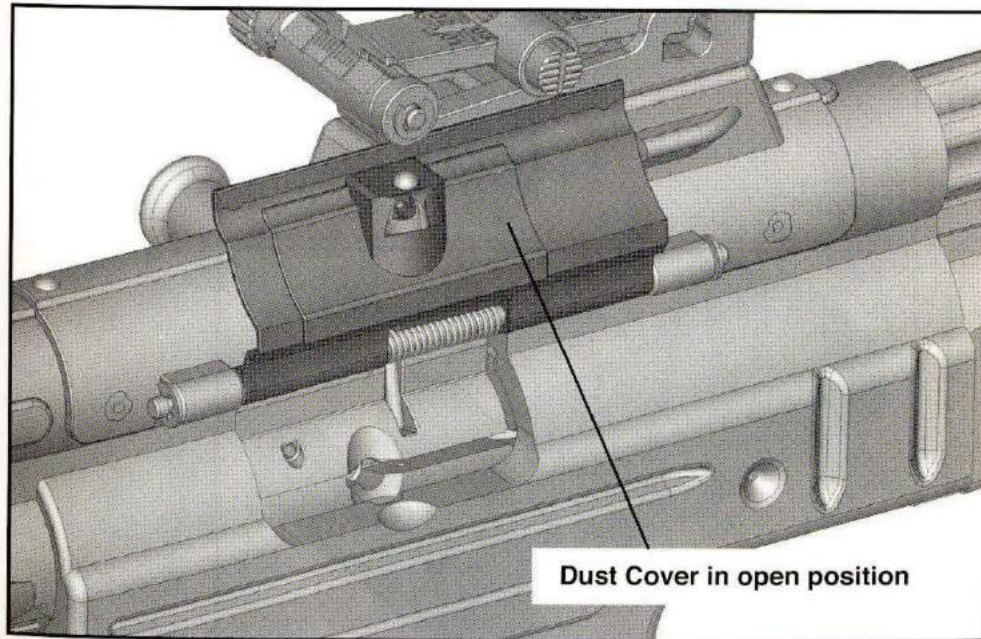

D-15: Adjusting the Sights

Procedure:

1. Push the button for Elevation adjustment, move the sight up or down and engage it into the required position.
Is the sight adjusted higher, it will result in a higher impact.
Is the sight adjusted lower, it will result in a lower impact.
2. The sight can be adjusted laterally by pulling and rotating the knob.
If shots are not to the right, turn the knob clockwise, shots will move left. (see Figure 3 page 20)
If shots are to the left, turn knob counter-clockwise, shots will move right. (see Figure 4 page 20)

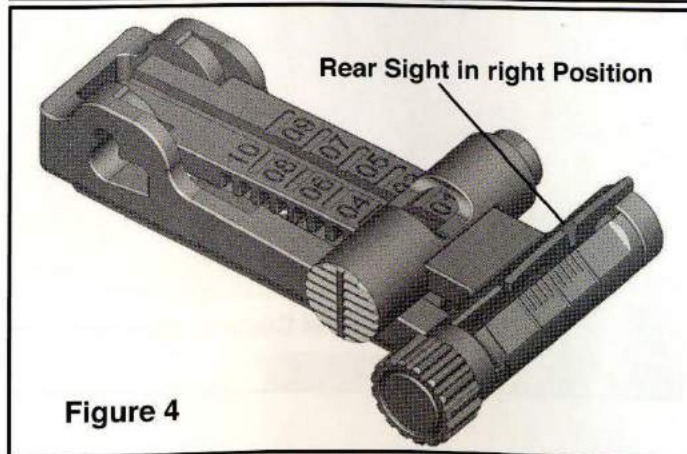
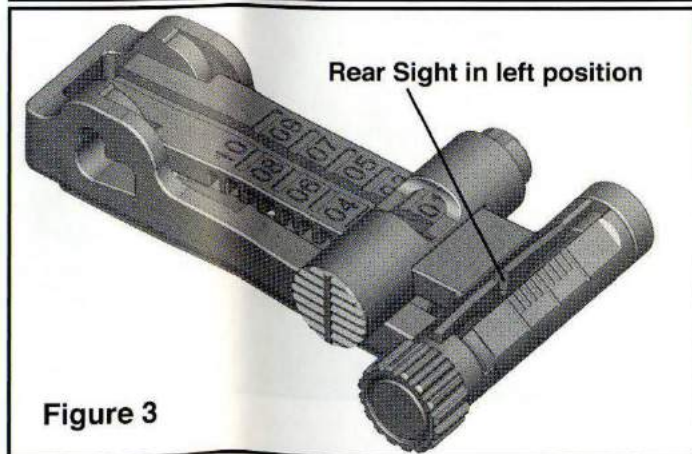
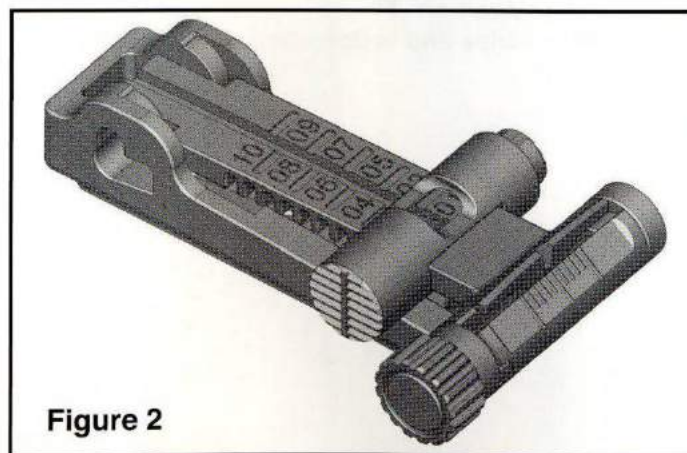
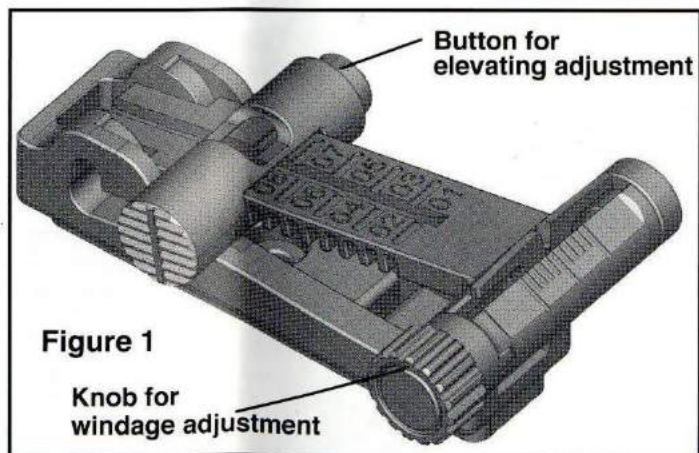

D-16: Maintenance and Disassembly the Weapon

Notice:

- Before disassembling, remove the magazine.
- Check, to make sure the rifle is unloaded and that there is no round in the chamber, before you begin cleaning it.

Procedure:

1. Remove the take down pin (see Figure 1 & 2 on page 22)
2. Hold the end of the receiver as you fold down the frame. NOTE! The receiver end cap is under spring pressure (see Figure 3 on page 22)
3. The system parts can be removed now. (see Figure 4 on page 22)

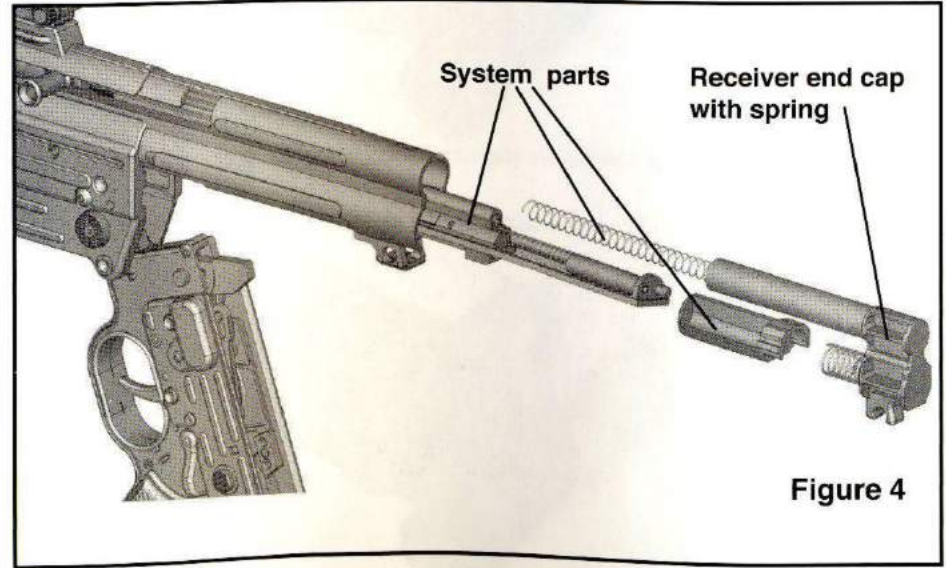
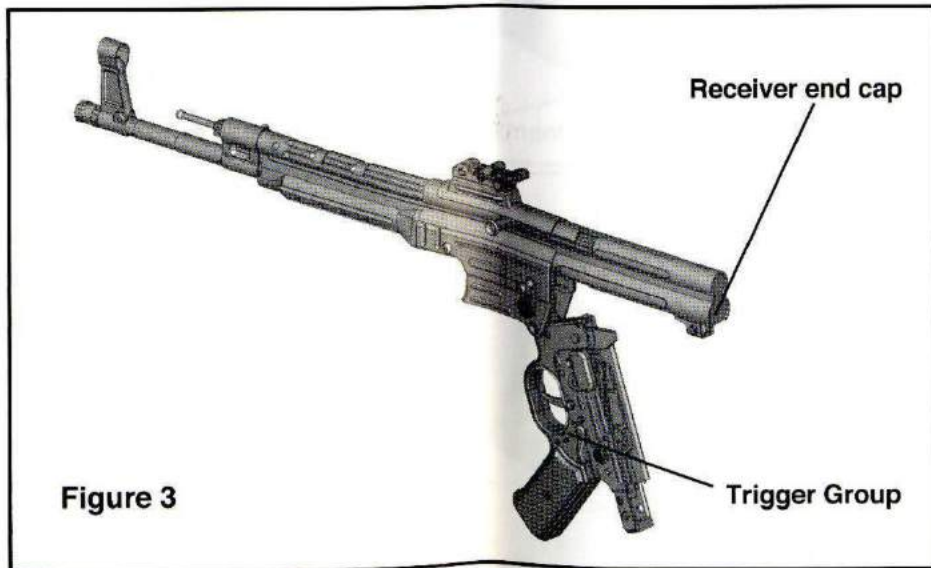
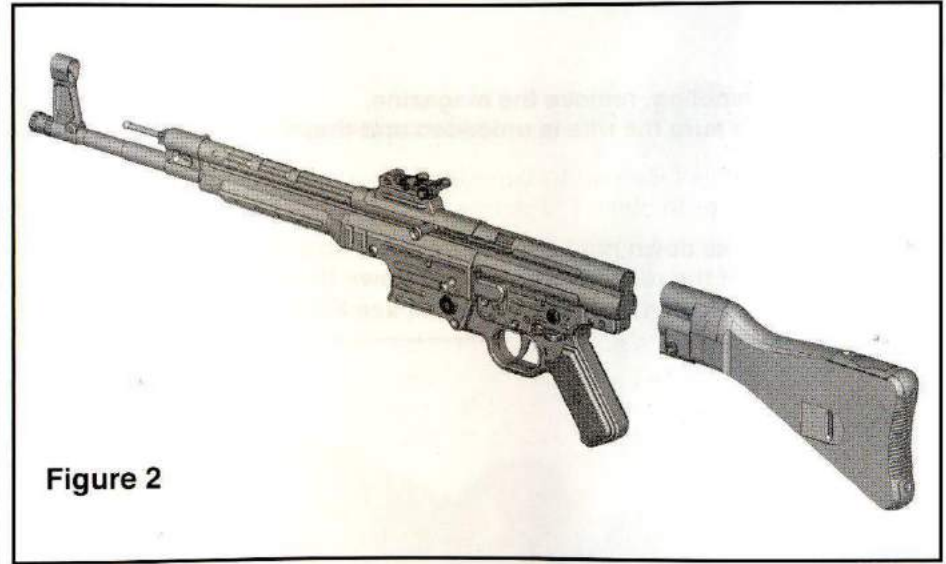
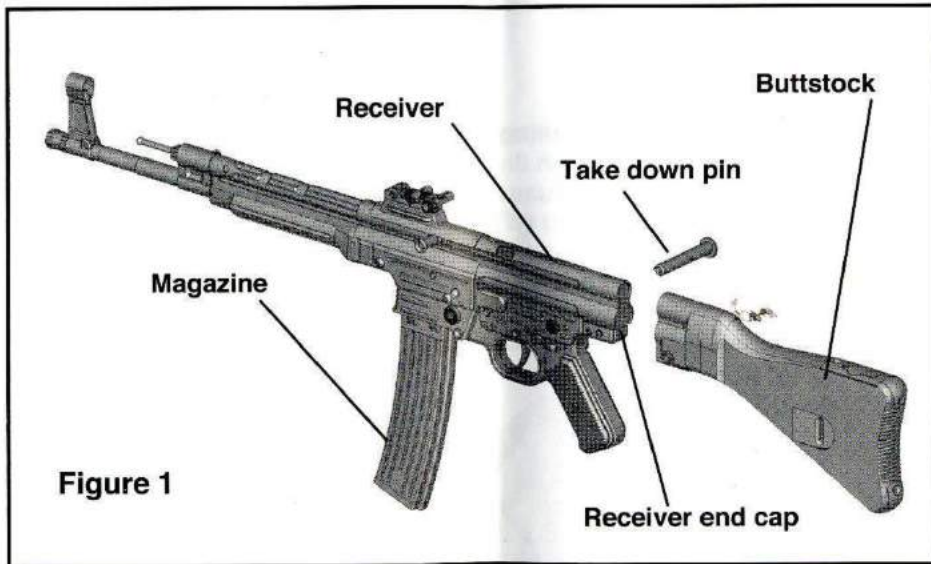

D-17: Cleaning of the Chamber and the Breech Block

Notice:

- The previously shown disassembling is sufficient for a overall cleaning.
- A further disassembling of the rifle should only be made by qualified personal.
- Do not use a steel brush or any other hard material to clean the barrel.
- Use only a suitable cleaning rod and brushes of the right caliber.
- Do not use thinner to clean the gun.

Procedure:

1. Use the cleaning brush to carefully remove all powder residues and dirt in the barrel and chamber. (see Figure 7 on page 23)
2. Wipe powder residues and oil from the barrel bore and chamber with cleaning patches.
3. Remove dirt from the breech block. (see Figure 8 on the page 23)
4. Lightly oil bore of chamber, with a few drops oil on a cleaning patch.
5. Insert the cleaning rod into the barrel with a clean patch to remove any excess oil.

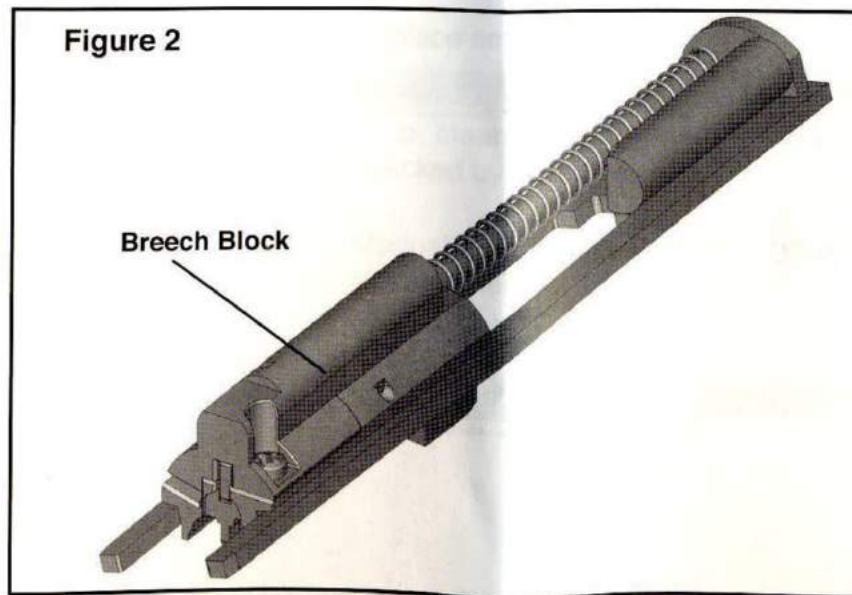
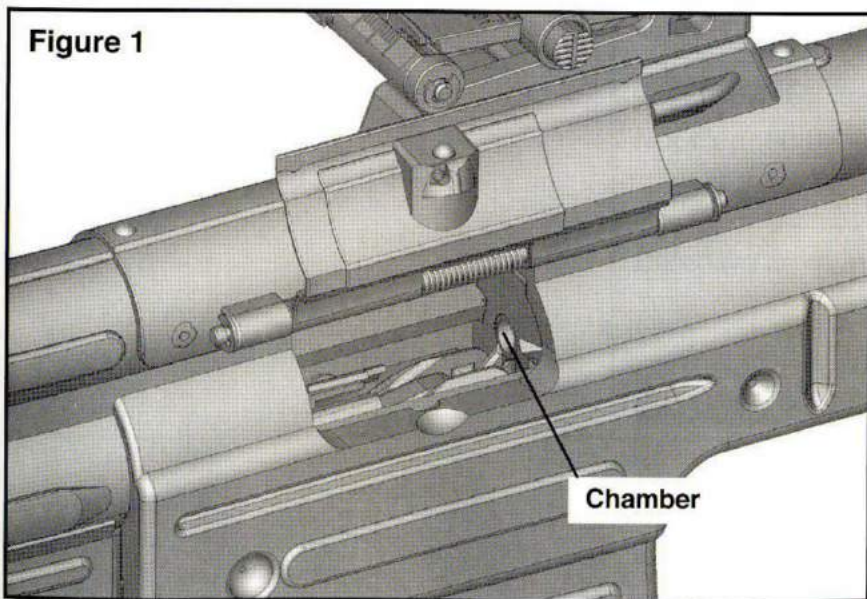

D-18: Care of the gun

Notice:

- Always keep your gun in immaculate condition and in good working order.
- Always clean and oil your gun after use.
- Never modify or repair parts of your gun yourself.
- Have your gun checked once every 12 month by a qualified gunsmith or armourer because defects, wear, corrosion, etc. are not always visible from the outside.
- If you order spare parts without returning the gun, you are responsible for ordering the correct part and its correct fitting by a qualified gunmaker or armourer
- Gun maintenance (cleaning and inspection) according to the instructions can prevent malfunctions. Should nevertheless, a malfunction occur during shooting, proceed as follows:

D-19: Troubleshooting / Removal

Part / Fault	Possible cause of fault / defect	Possible fault / defect removal
Ammunition feed: No round chambered	Magazine not properly inserted or dirty.	Insert Magazine properly or replace it.
Breech: Breech does not close properly.	Gun or round dirty or too heavily greased.	Strip, clean and lubricate rifle. Clean or replace ammunition.
	When Rifle still defective →	Repair by manufacturer / gunmaker
Case ejection: Spent case sticks in chamber or jams in ejection port.	Recoil insufficient because of fouling. Underloaded ammunition.	Strip, clean and lubricate rifle. Remove case with a cleaning rod. Replace ammunition
	When Rifle still defective →	Repair by manufacturer / gunmaker
Misfire: Hammer strikes, but no discharge	Not cleaned properly Defective ammunition	Strip, clean and lubricate rifle. Have gun checked by armourer. Manually cycle slide to chamber new round. Use another kind of ammunition.
	When Rifle still defective →	Repair by manufacturer / gunmaker

D-20: Storage of the gun

Notice:

- Always store your gun unloaded and in a cleaned condition.
- Store your gun separately from its ammunition and under lock and key in a gun safe corresponding to individual laws of your country.
- The gun and ammunition must be accessible to children and other inexperienced or unauthorized persons.

D-21: Shipping the gun

Warning:

Familiarize yourself fully with local legislation governing the shipping and transportation of firearms.

Procedure:

1. Check the gun to ensure that it is unloaded in a safe position and decocked.
2. Pack the gun well (if possible in its original packaging) to prevent damage in transit.
3. To prevent the gun being recognized as such during shipping, rap the original packaging in a second outer layer.
4. Do not include accessories.
Enclose a letter stating the following:
 - your full name
 - your full address (mention street, not P.O. Box)
 - your daytime telephone number
 - detailed description of the problem encountered or the service work to be performed.
5. Send the gun properly insured and carriage-paid (Packages without correct postage will not be accepted) to:
 - The sales outlet where you purchased the gun.
 - the GSG agent (importer) for your country.

Service & Distribution in USA

American Tactical Imports Inc.
100 Airpark Drive
Rochester, NY 14624
United States of America
www.americantactical.us
sales@americantactical.us
Phone: 585.328.2212
Fax: 585.328.8184

D-22: Accessories

01. Magazine 15 round
02. Magazine 10 round
03. Magazine 2 round

D-23: Disposal

- Strictly observe any current national or local regulations regarding the disposal of handguns.
- When shipping the gun due to above mentioned national legislation is allowed, we suggest to send gun for disposal to address mentioned under „Shipping the gun“.
- Follow instructions in the chapter „Shipping the gun“

D-24: Spare Part List (find under www.gsg-guns.com)

Necessary information for ordering spare parts:

- Type of gun (caliber, Model)
- Serial number
- Description
- In the United States under www.americantactical.us

Service & Distribution

American Tactical Imports Inc.

100 Airpark Drive

Rochester, NY 14624

United States of America

www.americantactical.us

sales@americantactical.us

Phone: 585.328.2212

Fax: 585.328.8184

Hersteller / Manufacturer

German Sport Guns GmbH

Oesterweg 21

59469 Ense-Höingen

Germany

www.gsg-guns.com

www.germansportguns.de

info@germansportguns.de

Phone: +49 (0) 2938-97839-0

Fax: +49 (0) 2938-9789-117